

User Manual

Artsen Plus / Pro Series



Fully digital IGBT converter CO₂/MAG/MIG multi-function welding power source User Manual

Model: Artsen Plus/Pro

Version No.: V1.1

Serial No.: R33010579

Shenzhen Megmeet Welding Technology Co., Ltd. will provide all-round technical support for our customers, including but not limited to: welding machine group control, robotic coordination, upgrading the software for welding technique database and after-sales services. Customers can contact any office or customer service center of Shenzhen Megmeet Welding Technology Co., Ltd. in the vicinity, or directly contact the headquarters of our company.

© Shenzhen Megmeet Welding Technology Co., Ltd. with all rights reserved.

We may make any change to the contents of this manual without prior notice.

Shenzhen Megmeet Welding Technology Co., Ltd.

Address: Floor 5th, Block B, Unisplendour Information Harbour, Langshan Road, North Zone, Science and Technology Park, Nanshan District, Shenzhen, Guangdong Province

Post code: 518057

Website: www.megmeet.com

Customer service line: 4006662163

Email box: Welder.4S@megmeet.com

Preface

Thank you for purchasing a fully digital IGBT converter CO₂/MAG/MIG multi-function welding power source (hereinafter referred to as the welding power source) produced by Shenzhen Megmeet Welding Technology Co., Ltd.

This manual gives our customers the information about installation and wiring, parameter setting, failure diagnosis and trouble-shooting for the machine, and the relevant precautions for daily maintenance. In order to correctly install and operate the welding power source and best realize its excellent performances, please read this manual carefully and completely.

Shenzhen Megmeet Welding Technology Co., Ltd. will further improve this product by research and development and innovation, therefore if there is any difference between the contents, parameters and figures in this manual and those of the real product, the real product should prevail. We may make any change without prior notice. This company has the right of final interpretation of this manual.

Precautions for safety

Safety definition

In order to use the welding power source safely and correctly and avoid any personal injury or property damage, this manual will use various warning identifications, and you should fully understand and strictly follow the relevant instructions.

The following identifications are categorized for warning purpose according to the specific hazard or damage levels.



Danger

Operating as required; otherwise death or serious injury may be caused.



Caution

Operating as required; otherwise moderate or minor injury or property damage may be caused.

Precautions for installation

Danger

- Before handling or moving the welding machine, the input power source from the electric distribution box must be cut off.
- Ensure that the lifting eye rings have been tightened by rotating and the enclosure and covering plates of the machine have been installed when using a hoist to handle the welding machine.
- Welding machine should not be hoisted together with another object.
- Install welding machine on a non-flammable object, and keep it far away from any flammable material; otherwise there is a risk of fire.
- Do not install the welding machine in an environment that is rich in explosive gas; otherwise there is a risk of explosion.
- Wiring should be done by qualified professional people; otherwise there is a risk of electric shock.
- Wiring should not be done until it is ensured that input power source has been turned off; otherwise there will be a risk of electric shock.
- Before powering on, the grounding terminals of the welding power source must be reliably grounded; otherwise there is a risk of electric shock.
- Before powering on, the covering plates must be placed properly; otherwise there is a risk of electric shock.
- Do not touch the terminals by hand when the machine is working; otherwise there is a risk of electric shock.
- Do not operate the welding machine with a wet hand; otherwise there is a risk of electric shock.
- Maintenance should be carried out after 5 minutes since the power source having been turned off when the indicator for welding power source has thoroughly been out and the voltage between positive bus and negative bus is less than 36 V; otherwise there is a risk of electric shock.
- Replacement of any part should be done by professional people and it is forbidden to leave any wire residue or metal object in the machine; otherwise there is a risk of fire.
- The parameters must be set correctly before running of the machine after replacement of control panel; otherwise there is a risk of property damage.
- The cable joint wiring should be wrapped with insulation tape; otherwise there is a risk of electric shock.
- Power source plug of water tank is of high voltage of AC 380V, the welding power source should be turned off before being wired; otherwise there is a risk of electric shock.

Caution

- Do not make the operation panel or covering plate under any force when handling when you moving the power source; otherwise falling down of such objects may cause personal injury or property damage.
- Make sure the trolley wheels firmly fixed when using a forklift to handle the welding machine..
- You should use a place that can withstand the weight of welding power source when installing; otherwise falling down of such machine may cause personal injury or property damage.
- It is forbidden to install the welding power source at a place where there is water spatter; otherwise there is a risk of property damage.
- Do not let any screw, gasket and metal rod and the like foreign object drop into the inside of the welding Power source; otherwise there are risks of fire and property damage.
- When the welding machine is damaged or of incomplete parts, do not install and use such machine; otherwise there are risks of fire and personal injury.
- The connection between the main circuit terminals and wire jointing sleeves must be firm; otherwise there is a risk of property damage.

Precautions for use

Danger

- In order to ensure safety, only personnel who have safe operation knowledge and welding skills can do welding operations.
- Welding power source should not be used for the other usage.
- Installation, commissioning and maintenance of welding power source should only be done by professional personnel.
- Those who use a cardiac pacemaker should not be close to welding power source and welding place without a permission from a doctor.
- Do not touch any live parts; otherwise there is a risk of electric shock.
- Do not use any cable that features insufficient sectional area, conductor exposed or damaged part.
- Do not remove the enclosure or cover of welding power source during using the machine.
- Use only undamaged, good-insulation gloves.
- When working high above the ground, the operator should pay attention to safety protection.
- When the welding power source is not used, please cut off the power supplies for welding power source and electric distribution box.
- When welding in a narrow or enclosed space, the operator should be supervised by a checker in ensuring sufficient ventilation or wearing breathing protective apparatus; otherwise asphyxia may be caused due to lack of oxygen.
- There will be some harmful fume and gas during welding, so please have sufficient ventilation or wear breath protective apparatus; otherwise health will be endangered.
- Do not weld the pressurized containers such as pipe filled with gas and sealed container.
- Do not place a hot working piece close to some flammable material.
- Do not weld something in the vicinity of some flammable material.
- Do not place a fire extinguisher in the vicinity of the welding placed.
- Dedicated holder should be used for fixing gas cylinder; otherwise toppling and falling of gas cylinder may cause personal injury.
- Do not have electrode contact gas cylinder.
- Please correctly use the pressure relief valve as required.
- Disassembling, repairing and maintenance of pressure relief valve should be done by professional personnel.

- Do not touch any rotating parts like working fans or wire-feeders; otherwise personal injury may be caused.
- Ensure that the operator or checker use the protective device with enough arc light shielding to avoid the arc light damaging the eyes or skin when welding or supervising welding process.
- Please use dedicated protective leather gloves, long-sleeved clothes, welding spats, apron goggles and other protective devices for welding. Avoid arc light, spills and welding slags causing any damages.
- Protective shield should be set up around the welding place, to avoid arc light causing any damages to others.
- Acoustic insulation device should be used to avoid any noise damages.

Caution

- It is forbidden to use this welding power source for the task other than welding.
- Do not place any heavy objects on the welding power source.
- Do not block or jam the ventilation holes of the welding power source.
- Put the welding power source at a place where the metal foreign objects such as metal spills are unable to drop into the inside of the welding power source.
- Keep the distance between the welding power source and the wall or other welding power source be 30 cm or more.
- To avoid the wind directly blowing electric arc, some shield should be used.
- Please firmly fix the wheels to avoid the welding power source sliding.
- To avoid electromagnetic hazards, electromagnetic shielding should be applied to cables or welding place.
- Inclination angle of the plane where the welding power source is placed should be less than 15 degrees to avoid the welding machine toppling.
- The protection level of this welding machine is IP 23S, and the working conditions for usage should be required as follows:
 Working temperature range: $-10^{\circ}\text{C} \sim +40^{\circ}\text{C}$
 Transportation and storage temperature range: $-40^{\circ}\text{C} \sim +70^{\circ}\text{C}$
 Working humidity range: at 40°C , no more than 75%RH; at 20°C , no more than 95%RH.
 Height above sea level should not be more than 2000 m.
 There should be no remarkable mechanical vibration and impact and the inclination angle of the welding machine should not be more than 15 degrees.
 Contents of dust, metal powder and corrosive gas in the ambient air should be within a normal scope.
 Prevent the welding power source from being rained on or the fan from inhaling raining water.
- Using the dedicated antifreeze for the water tank when the ambient working temperature is lower than 10°C ; Otherwise the water tank may be damaged.

Precautions for abandonment

The following issues should be noted when scraping the power source:

- The electrolytic capacitor on the main circuit may be explode when being incinerated.
- There will be toxic gases when incinerate the plastic or rubber parts of the panel.
- The welding power source should be disposed as industrial waste.

Contents

Chapter 1 General Information.....	11
1.1 Introduction of welding power source and system	11
1.2 System composition	11
1.3 Explanation of model coding.....	12
1.4 Configuration explanation	13
1.5 Dimensions.....	13
1.6 Technical parameters	15
1.6.1 Welding process.....	15
1.6.2 Duty cycle.....	16
Chapter 2 Installation and wiring	18
2.1 Inspection after unboxing	18
2.2 Installation conditions	18
2.3 Precautions for handling.....	18
2.4 Requirements of input power	19
2.5 Electrical wiring procedures.....	19
2.5.1 Connection of the welding power source	20
2.5.2 Connection of the wire-feeder	21
2.5.3 Connection of the welding torch.....	21
2.5.4 Connection of the push-pull torch	22
2.5.5 Connection of the ground cable.....	23
2.5.6 Connection of the voltage feedback cable	24
2.5.7 Connection of the shield gas.....	26
2.5.8 Connection of the water cooler.....	27
2.5.9 Connection of input power cable (380V AC)	28
Chapter 3 Functions and operation.....	29
3.1 Setup panel	29
3.2 LED display.....	31
3.3 Inching.....	32
3.4 Gas check	33
3.5 Welding control	34
3.5.1 2 steps.....	34
3.5.2 Crater fill 4 steps	35
3.5.3 Special 4 steps	36
3.5.4 Spot welding.....	36
3.5.5 Intermittent welding	37
3.6 Water flow inspection	38
3.7 Burn-Back	39
3.8 Pre-gas.....	40
3.9 Pre-feeding	41
3.10 Starting arc	42
3.11 Crater	44
3.12 Wire retract.....	45

3.13 Post-gas supply.....	46
3.14 Inching.....	47
3.15 inchng Save parameters.....	47
3.16 Lock parameters	48
3.17 Clear parameters.....	48
3.18 Restore to factory settings and data.....	49
3.19 Manually switching JOB number.....	51
3.20 Upgrading the firmware with a USB flash disk.....	51
3.20.1 Preparations	51
3.20.2 General upgrading mode	52
3.20.3 Upgrading mode with a power bank.....	53
3.20.4 Communication Box firmware upgrade	54
3.20.5 Restoring to Factory default settings	55
Chapter 4 Configuration of welding power source features	56
4.1 Configuration of welding program parameters.....	56
4.1.1 Selection of control mode for the welding power source (P02).....	56
4.1.2 Activating the Water-cooling system for the welding power source (P03).....	57
4.1.3 Activating robotic communication module (P05).....	58
4.1.4 Selection of wire-feeder (P06).....	58
4.1.5 JOB display (P07).....	59
4.1.6 Crater fill ON/OFF (P08)	59
4.1.7 Activating water flow inspection (P09)	60
4.1.8 Activating LED display on wire-feeder (P10)	60
4.1.9 Activating low-spatter module (P11).....	61
4.1.10 Activating push-pull system (P12).....	61
4.1.11 Force adjustment of the pulling motor 1 (P13).....	62
4.1.12 Force adjustment 2 of the pulling motor (P14).....	62
4.1.13 Switch between displaying pre-set and realistic parameters (P15).....	63
4.1.14 Switch between displaying wire-feeding speed and welding Current (P16).....	63
4.1.15 Switching between welding mode (P17)	64
4.1.16 Activating the No-load protection (P19).....	64
4.1.17 Switching between displaying correction ratio and absolute value of wire-feeding (P20).....	65
4.1.18 Activation of weld penetration depth control (P21).....	65
4.1.19 Sensitivity adjustment of low-spatter module(P22).....	66
4.1.20 Activating parameter correction of welding circuit parameter (P23).....	66
4.1.21 Resistance compensation of welding circuit (P24).....	67
4.1.22 Inductance compensation for welding circuit (P25)	67
4.1.23 Activating twin-wire welding mode (P26).....	67
4.1.24 Adjustment of starting arc stabilization time (P27)	68
4.1.25 Adjustment of starting arc stabilization voltage (P28).....	68
4.1.26 Switch of duty cycle mode (P29).....	69
4.1.27 Checking software version of welding power source display broad (P30).....	69
4.1.28 Checking software version of motor drive broad (P31).....	70

4.1.29	Checking software version of welding power source control board (P32)	70
4.1.30	Checking software version of wire-feeder display board (P33).....	71
4.1.31	Checking software version of communication connection board (P34)	71
4.1.32	Checking software version of Ethernet communication connection Board/Box (P35)	72
4.1.33	Checking welding process software (P40).....	72
4.1.34	Checking power grade of welding power source (P41).....	73
4.1.35	Checking product series of welding power source (P42)	73
4.1.36	Checking input voltage type (P43)	74
4.1.37	Checking hardware code of welding power source (P50)	74
4.1.38	Checking bar code of welding power source (P51)	75
4.1.39	Adjustment of wire-feeding speed (P60)	75
4.1.40	On/Off switch of current wave correction for starting arc (P61)	76
4.1.41	Adjustment of inspection time of crater (P62).....	76
4.1.42	Activating constant opening of cooling fan (P63)	77
4.2	Configuration of welding network parameters	77
4.2.1	Configuration of robot protocol (N00)	77
4.2.2	Configuration of MAC ID of welding power source (N01)	78
4.2.3	Configuration of Robot MAC ID (N02).....	78
4.2.4	Baud rate of robot communication (N04).....	79
4.2.5	Reverse switch between low electrical level (0 for digital communication) and high electrical level (1 for digital communication) feedback signal of arc ignition (N05).....	79
4.2.6	Reverse switch between low electrical level (0 for digital communication) and high electrical level (1 for digital communication) ready signal of welding power source (N06)	80
4.2.7	Reverse switch between low electrical level (0 for digital communication) and high electrical level (1 for digital communication) for successful seam positioning (N07) ...	80
4.2.8	Switch between pre-setting welding current of wire-feeding speed (N08).....	81
4.2.9	Filter rate for welding parameters (N09)	81
4.2.10	Selection of welding mode (N10).....	82
4.2.11	Selection of network parameters (N11)	82
4.3	Configuration for channel parameters of the welding power source	83
4.3.1	Channel parameters	83
4.3.2	Description of channel parameters	84
Chapter 5	Communication interface with robot	87
5.1	Communication interface with robot	87
5.2	Analog interface	88
5.2.1	Configuration of parameter graph	91
5.3	DeviceNet.....	91
5.3.1	Definition of the connector pins	91
5.3.2	Configuration of communication.....	92
5.3.3	Configuration of parameter graph	92
5.4	EtherNet/IP	94
5.4.1	Configuration of EtherNet/IP communication.....	94

5.4.2 Advanced configuration of EtherNet/IP communication	95
5.4.3 Configuration of parameter graph	95
5.5 Data definitions for application layer	97
5.6 Operational procedure of robot.....	98
Chapter 6 Error diagnosis.....	99
6.1 Error code of welding power source and solution	99
6.2 Error code in firmware upgrading and solution.....	101
Chapter 7 Maintenance.....	102
7.1 Daily check.....	102
7.2 Periodic check	103
7.3 After-sales service	104
Appendix 1 Technical specification	105
Appendix 2 Electrical diagram.....	106
Appendix 3 System composition & Accessories Systematic configuration	107
Appendix 4 Structural Illustration	111

Chapter 1 General Information

1.1 Introduction of welding power source and system

Artsen Plus/Pro series fully digital IGBT converter CO₂/MAG/MIG multi-function welding power source has the following features:

- Short arc pulse transfer control technique which can realize high pulse welding;
- Special synergy welding with pulse control and direct current control can be realized;
- Various channel welding controls can be adjusted respectively;
- Coordinating control for push-pull wire feeding can be realized;
- 100kHz frequency controlling;
- Various communication ports can be used to connect the robot or intelligent equipment;
- It is supported to use a USB flash disk to upgrade the firmware of the welding power source;
- Compatible with light-weight manual wire-feeder or standard manual wire-feeder.

Additionally, for Artsen Plus:

- With current controlling module at the secondary side which can realize low spatter short-circuiting transfer welding.
- High speed intermittent welding can be realized.

1.2 System composition

Welding power source system consists of a welding trolley, a water tank, a wire-feeder, a gas supply system, positive output cable, ground cable, voltage feedback cable, welding torch and inter-connection cable set.

Manual welding power source can be upgraded to a robotic welding power source by directly inserting a card. The robotic version is shown in Figure 1-1, the manual version with a standard manual wire-feeder is shown in Figure 1-2, while the manual version with an light-weight manual wire-feeder shown in Figure 1-3.

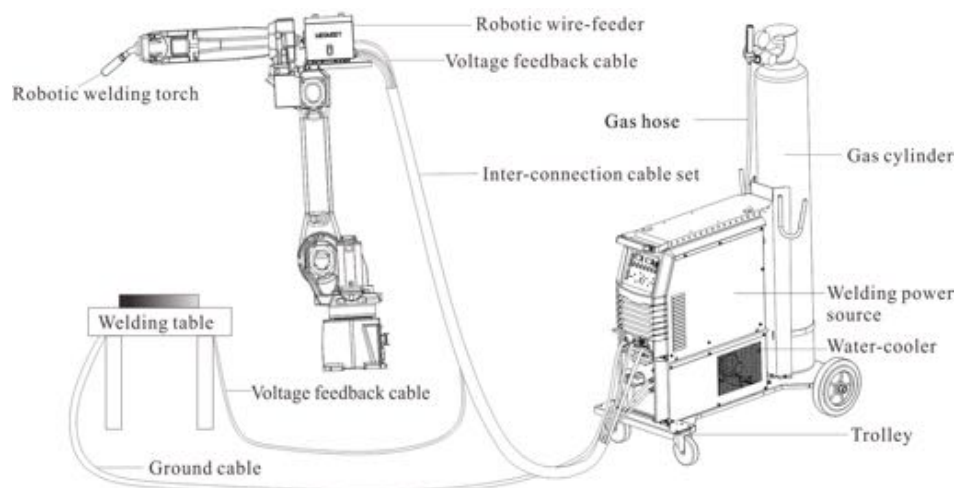

Figure 1-1 Configuration connection diagram for the robotic welding system

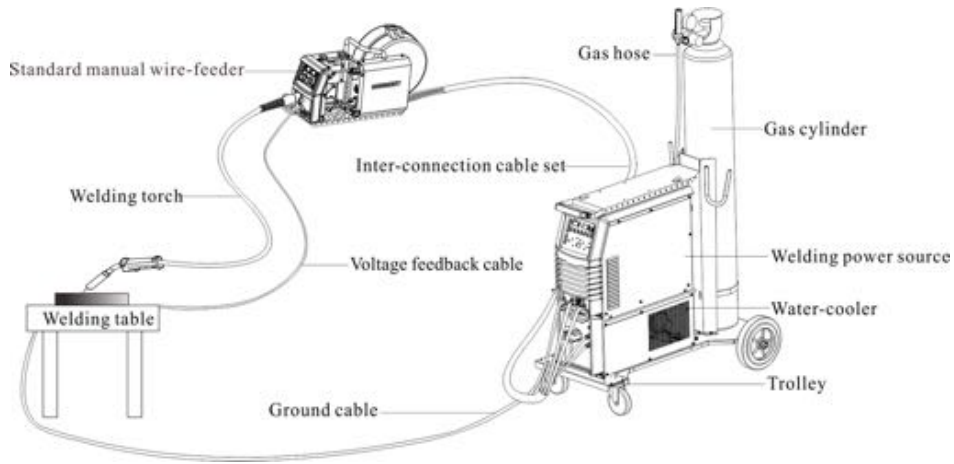

Figure 1-2 Configuration connection diagram for the manual welding system (With a standard manual wire-feeder)

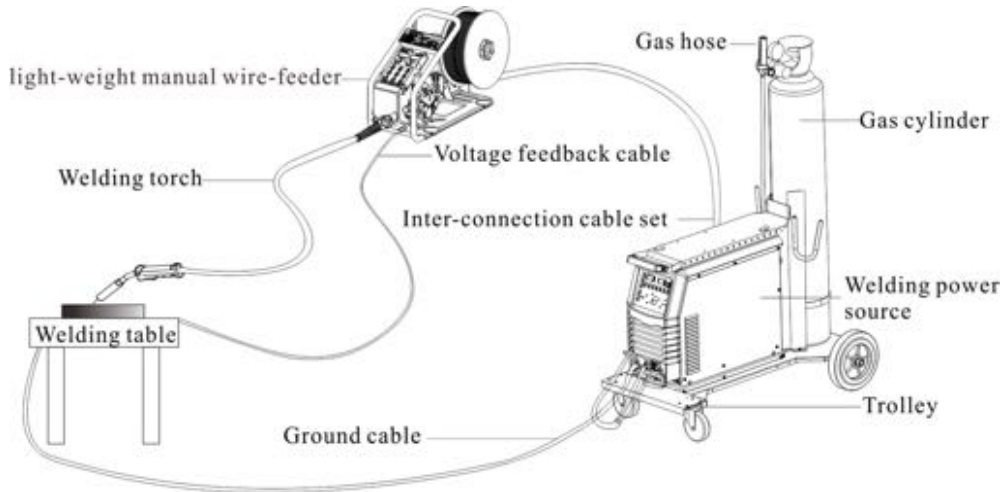

Figure 1-3 Configuration connection diagram for the manual welding system (With a light-weight manual wire-feeder)

1.3 Explanation of model coding

Model code explanation of Artsen Plus/Pro welding power source is shown in Figure 1-4.

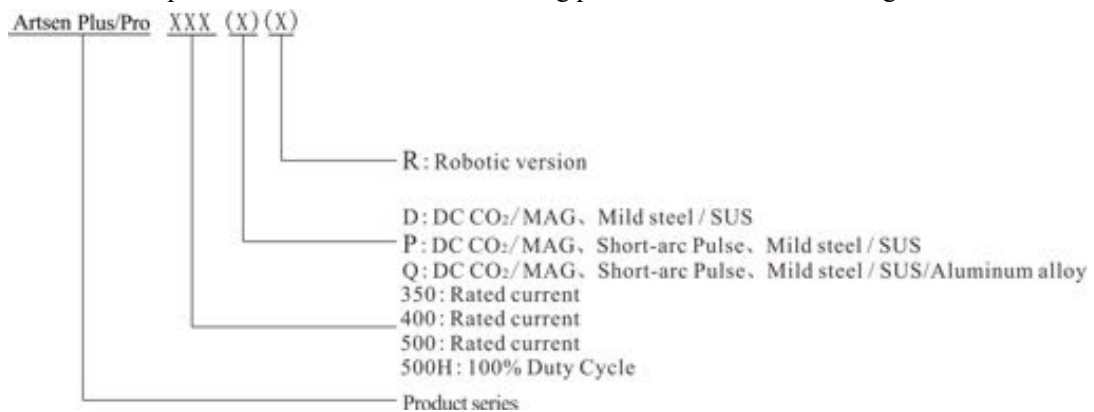

Figure 1-4 Model code explanation of Artsen Plus/Pro

※Note: The symbol in the “()” is optional, for representing different models of welding

power source.

•Example 1:

Artsen Plus 400Q means it is of the Artsen Plus series, including the welding techniques of direct current low spatter CO₂/MAG and short arc pulse welding, and the welding materials of carbon steel/stainless steel/aluminum alloy, and it is a manual welding power source with the rated current being 400A.

•Example 2:

Artsen Plus 500D means it is of the Artsen Plus series, including the welding techniques of direct current low spatter CO₂/MAG, and the welding materials of carbon steel/stainless steel, and it is a manual welding power source with the rated current being 500A.

•Example 3:

Artsen Pro 400Q means it is of the Artsen Pro series, including the welding techniques of direct current CO₂/MAG and short arc pulse welding, and the welding materials of carbon steel/stainless steel/aluminum alloy, and it is a manual welding power source with the rated current being 400A.

•Example 4:

Artsen Pro 500D means it is of the Artsen Pro series, including the welding techniques of direct current CO₂/MAG and the welding materials of carbon steel/stainless steel and it is a manual welding power source with the rated current being 500A.

1.4 Configuration explanation

For the details, see **Appendix 3 System configuration table for Artsen Plus/Pro.**

1.5 Dimensions

In this section, we will give an explanation about the specifications and outline dimensions of the manual welding power source, standard/light-weight manual wire-feeder and robotic wire-feeder, as shown in Table 1-1.

Table 1-1 Outline dimensions table for a welding power source and its accessories

Assembly unit name	Outline dimensions (Length*Width*Height) mm	Gross weight (kg)
Robotic wire-feeder	230*170*170	6
Standard manual wire-feeder	630*250*400	14.5
Light-weight manual wire-feeder	519*200*370	9.6
Welding power source	620*300*480	57.5

Outline dimensions of an standard manual wire-feeder are shown in Figure 1-5.

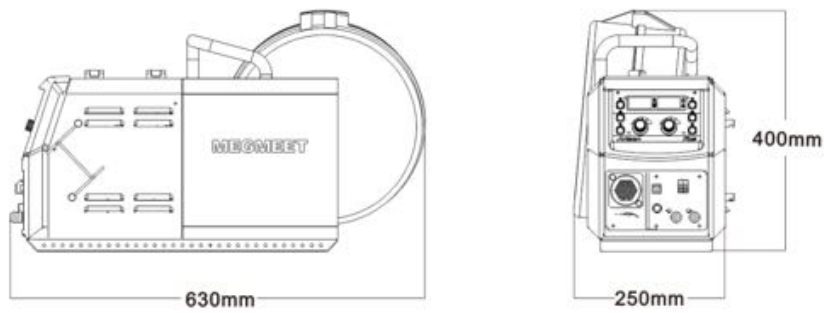

Figure 1-5 Outline dimensions of a standard manual wire-feeder

Outline dimensions of a light-weight manual wire-feeder are shown in Figure 1-6.

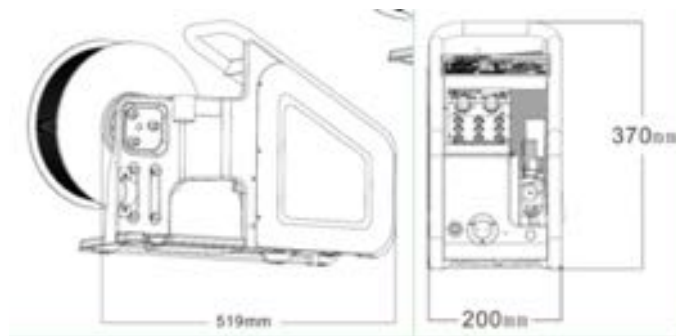

Figure 1-6 Outline dimensions of a light-weight manual wire-feeder

Outline dimensions of a robotic wire-feeder are shown in Figure 1-7.

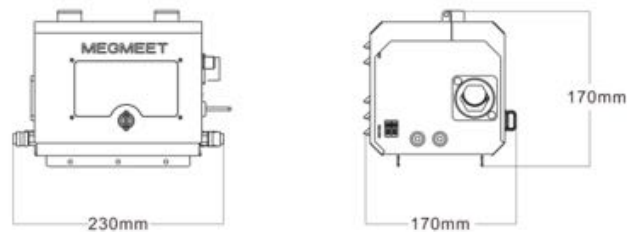

Figure 1-7 Outline dimensions of a robotic wire-feeder

Outline dimensions of a welding power source are shown in Figure 1-8.

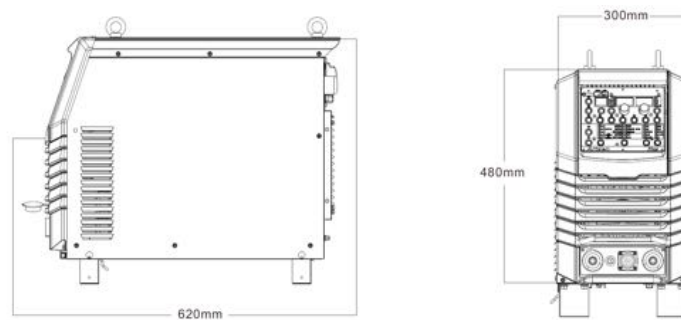

Figure 1-8 Outline dimensions of a welding power source

1.6 Technical parameters

For details, see the tables in Appendix 1 Technical specification.

1.6.1 Welding process

Low spatter short-circuiting transition welding technique is shown in Figure 1-9.

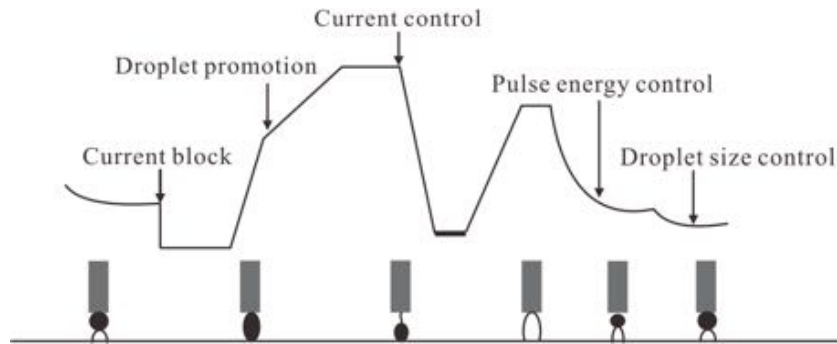

Figure 1-9 Low spatter short-circuiting transfer control technique

Short arc pulse technique is shown in Figure 1-10.

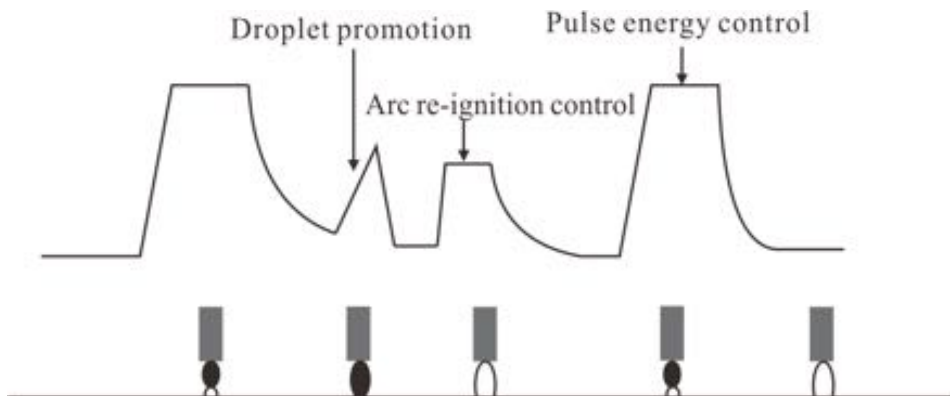

Figure 1-10 Short arc pulse transfer control technique

Double pulses technique is shown in Figure 1-11.

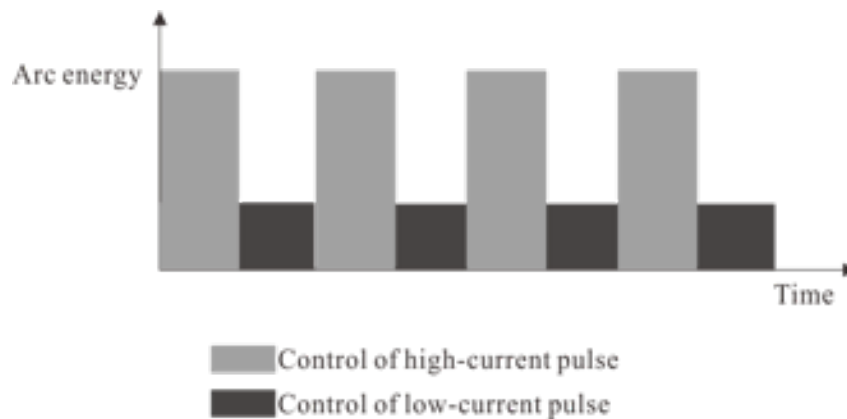

Figure 1-11 Double pulses transfer control technique

DP synergy short arc pulse technique is shown in Figure 1-12.

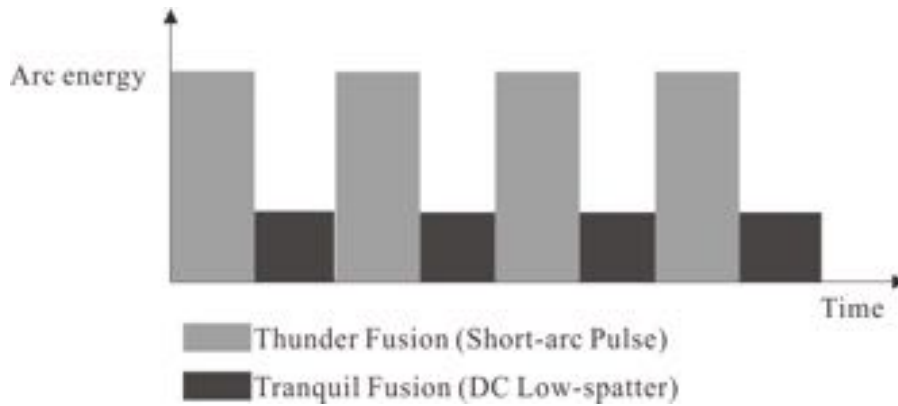

Figure 1-12 DP synergy transition control technique

Table 1-2 Software configuration for Artsen Plus welding power source

Model	Software package	Welding material	Technique type	Synergy	High-speed Intermittent welding	Special synergy
Artsen Plus 350/400/500D(R)	D	Solid carbon steel, solid stainless steel	Short-circuiting transfer with low spatter	no	no	no
Artsen Plus 350/400/500D(R)	DD	Solid carbon steel, solid stainless steel	Short-circuiting transfer with low spatter	no	yes	no
Artsen Plus 350/400/500P(R)	PP	Solid carbon steel, solid stainless steel	Short-circuiting transfer with low spatter, short arc pulse	yes	yes	no
Artsen Plus 350/400/500P(R)	DP	Solid carbon steel, solid stainless steel	Short-circuiting transfer with low spatter, short arc pulse	yes	yes	yes
Artsen Plus 350/400/500Q(R)	A	Solid carbon steel, solid stainless steel, aluminum alloy	Short-circuiting transfer with low spatter, short arc pulse	yes	yes	yes

Table 1-3 Software configuration for Artsen Pro welding power source

Model	Software package	Welding material	Technique type	Synergy	Special synergy
Artsen Pro 350/400/500(H)D(R)	D	Solid carbon steel, solid stainless steel	Short-circuiting transfer	no	no
Artsen Pro 350/400/500(H)P(R)	PP	Solid carbon steel, solid stainless steel	Short-circuiting transfer, short arc pulse	yes	no
Artsen Pro 350/400/500(H)Q(R)	A	Solid carbon steel, solid stainless steel, aluminum alloy	Short-circuiting transfer, short arc pulse	yes	no

1.6.2 Duty cycle

Duty cycle for Artsen Plus/Pro

The duty cycle refers to the time as a percentage of a ten-minute period that you can weld or cut at a certain load without overloading, as shown in Figure 1-13.

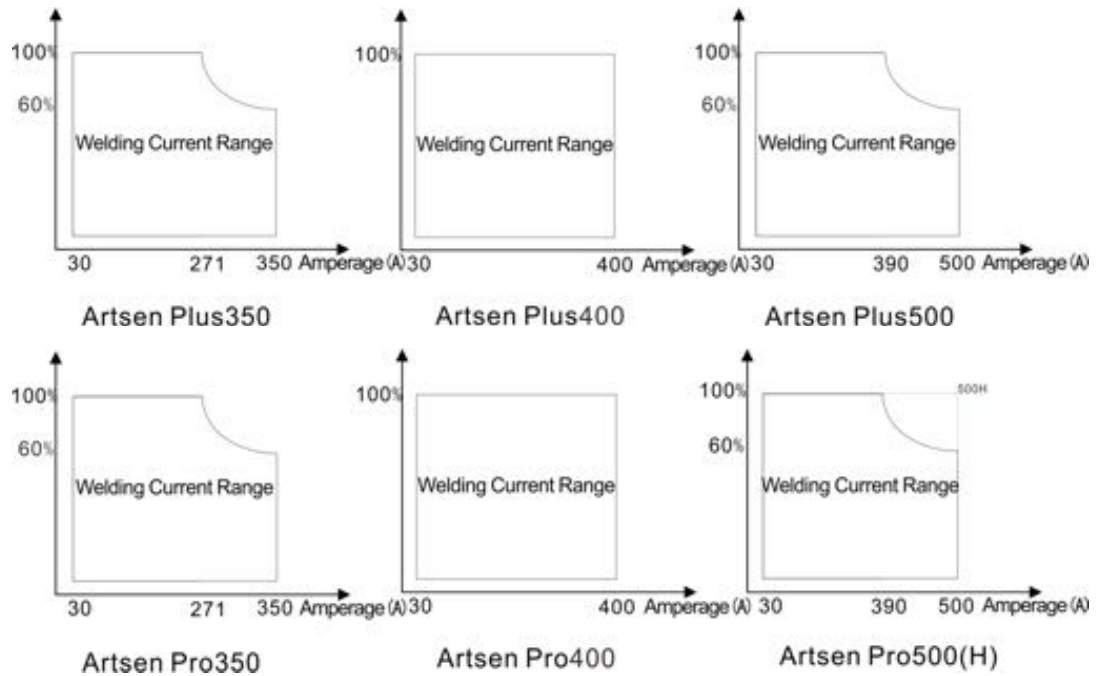

Figure 1-13 Artsen Plus/Pro Duty cycle

Note:

X = 60% (direct current): in a duration of 10 minutes, the welding power source can work continuously for 6 minutes at its rated direct current output status.

X = 100% (direct current): in a duration of 10 minutes, the welding power source can work continuously for 10 minutes at its rated direct current output status.

Warning about safety

1. Please use the welding power source within its rated duty cycle scope; if the rated duty cycle is exceeded, the welding power source may be burned out.
 2. Ensure a good ventilation for the welding power source and clean up the dust around it to guarantee the power source working on its normal duty cycle.
-

Chapter 2 Installation and wiring

This chapter will describe the installation requirements for a welding power source, and the relevant steps and precautions.

2.1 Inspection after unboxing

1. Check if the external package of the product is intact before opening the package,.
2. Please confirm that the accessories are complete and make sure the model is the same as the order after opening the package.

2.2 Installation conditions

Environmental requirements

- Please follow the items below when choosing the installation environment.
 - The machine should be installed in a place where there is a good ventilation and the vibration is less than 5.9 m/s^2 (0.6 g).
 - Avoid installing the power source in a place with much dust and metal powder.
 - It is forbidden to install the machine in a place where there is corrosive and explosive gas.
 - The ambient temperature should be within the scope of $-10^\circ\text{C} \sim +40^\circ\text{C}$; Forced external heat dissipation should be applied or the machine should be used at lower rated power when the temperature is over 40°C .
 - The humidity should be less than 95%, and there is no condensed water drop.
 - Wind prevention should be applied for the welding place, and when necessary the windshield should be used; otherwise the welding technique will be affected.
- If there is any special installation requirement, please make a consultation in advance.

Requirements for installation space

There should be at least a distance of 20 cm from the welding power source to the wall; when several machines are to be aligned in a line, the distance between every two adjacent machines should more than 30 cm. The reserved space for placing welding power source is recommended in Table 2-1.

Table 2-1 Reserved space for installation of welding power source

	Front	Top	Left	Right	Back
Reserved space	$\geq 20 \text{ cm}$	$\geq 10 \text{ cm}$	$\geq 20 \text{ cm}$	$\geq 20 \text{ cm}$	$\geq 20 \text{ cm}$

2.3 Precautions for handling

- 1., The input power from the electric distribution box must be cut off before handling the welding power source.
2. The trolley wheels must be firmly fixed when handling the welding power source with a forklift.
3. There is some risk in lifting the welding power source for installation, and it is not recommended to use a hoist for installation.

2.4 Requirements of input power

The specifications of input power for Artsen Plus/Pro series welding power source are shown in Table 2-2.

Table 2-2 Specifications for power supply

Items		Model Power		
		Artsen Plus/Pro 350	Artsen Plus/Pro 400	Artsen Plus/Pro 500(H)
Rated input voltage		Three-phase AC 380V	Three-phase AC 380V	Three-phase AC 380V
Input frequency		50Hz/60Hz	50Hz/60Hz	50Hz/60Hz
Power supply capacity	Grid power supply	$\geq 30\text{kVA}$	$\geq 30\text{kVA}$	$\geq 30\text{kVA}$
	Generator power supply	$\geq 50\text{kVA}$	$\geq 50\text{kVA}$	$\geq 50\text{kVA}$
Input protection equipment (electric distribution box)	Circuit-breaker	C class, $\geq 40\text{A}$	C class, $\geq 63\text{A}$	C class, $\geq 63\text{A}$
Cable	The input side of welding power source	$\geq 10\text{mm}^2$	$\geq 16\text{mm}^2$	$\geq 16\text{mm}^2$
	The output side of welding power source	$\geq 35\text{mm}^2$	$\geq 50\text{mm}^2$	$\geq 50\text{mm}^2$
	The earth wire for machine enclosure	Equivalent to or more than the input side of welding power source	Equivalent to or more than the input side of welding power source	Equivalent to or more than the input side of welding power source

Note: the specifications of power supply for robotic series welding power source are the same as that shown in the above.

Warning about safety

Please install the leakage protector when you operating on an iron plate or frame in a wet working place.

2.5 Electrical wiring procedures

Steps:

1. Output side cable connection of welding power source (See 2.5.1 Connection of the welding power source for more details.)
2. Wire-feeder connection (See 2.5.2 Connection of the wire-feeder connection for more details)
3. Connection for welding torch (See 2.5.3 Connection of the welding torch for more details)
4. Connection for the feedback cable of the welding torch (See 2.5.4 Connection of the feedback cable of the welding torch for more details)
5. Pushing-pulling wire port connection (See 2.5.5 Connection of the Push-pull torch for more details)
6. Working piece side positive output cable (ground cable) connection (See 2.5.6 Connection of the ground cable for more details)
7. Connection for the voltage feedback cable (See 2.5.7 Connection of the voltage feedback

cable for more details)

8. Protective gas connection (See 2.5.8 Connection of the shield gas for more details)
9. Water cooling device connection (See 2.5.9 Connection of the water cooler for more details)
10. Input power cable connection (See 2.5.10 Connection of input power cable for more details)

※Note: The water cooling device falls out of a standard configuration, customers can buy it according to the individual needs.

Warning about safety

1. Have qualified professional electrical operator do the connection operations.
 2. Please wear the relevant protective items, such as the protective gloves, boots and long-sleeve smock.
 3. Electrical connection should only be done under the condition that the switch on the electric distribution box has been turn off and safety is ensured.
 4. Use only the cables of defined specifications. Do not touch the live parts of the welding power source, such as input and output terminals.
 5. Ensure connect the welding power source to the electrical earth reliably .
-

2.5.1 Connection of the welding power source

Steps:

1. Connect the welding cable connector to the positive pole of welding power source, and fasten the connection;
2. Plug the wire-feeder control cable into the socket of the welding power source and fasten it as shown in Figure 2-1.

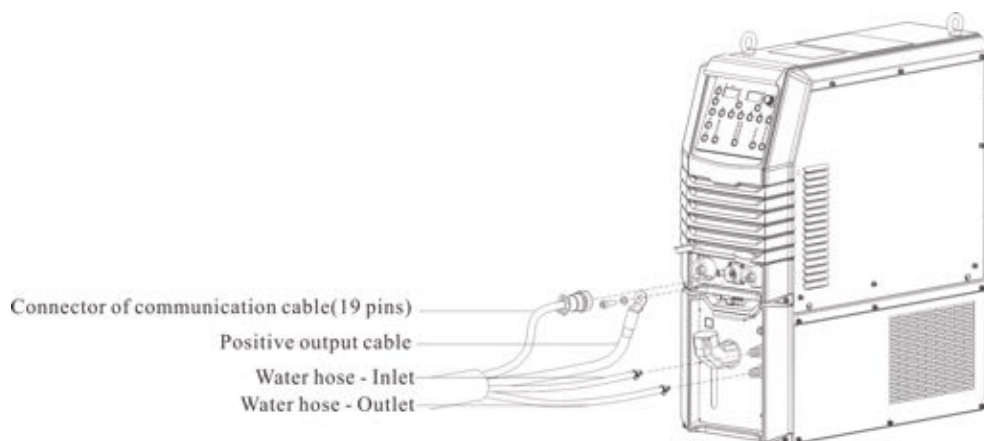

Figure 2-1 Connection of the welding power source

2.5.2 Connection of the wire-feeder

Steps:

1. Loosen the buckle at the end of wire-feeder, and firmly fix the welding cable on the bolt at the bottom plate of wire-feeder with a nut;
2. Turn the wire-feeder control cable firmly on the socket;

Robotic wire-feeder connection is shown in Figure 2-2.

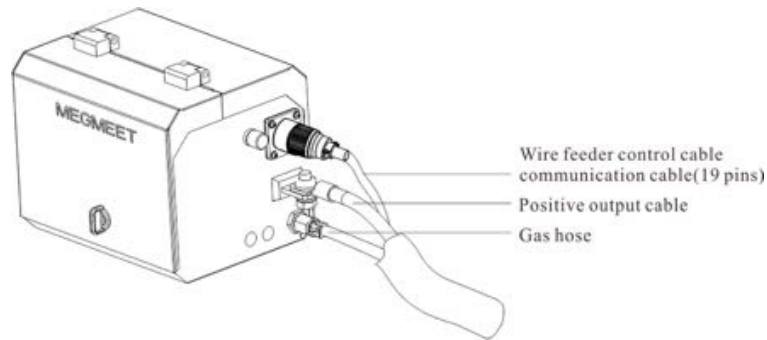

Figure 2-2 Robotic wire-feeder connection

Manual wire-feeder connection is shown in Figure 2-3.

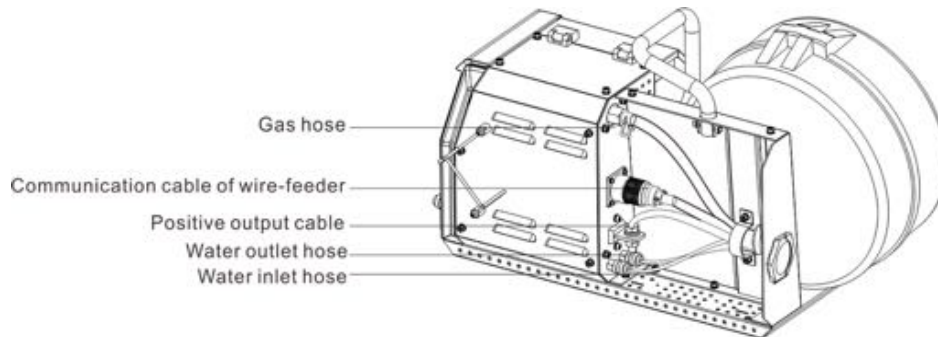

Figure 2-3 Manual wire-feeder connection

2.5.3 Connection of the welding torch

Steps:

1. Fix the welding torch to the port for the welding torch on the wire-feeder;
2. Fix the control cable of the wire-feeder to the port for the inspection cable on the wire-feeder, completing the fixing and inspection of the welding torch.

Robotic welding torch connection is shown in Figure 2-4.

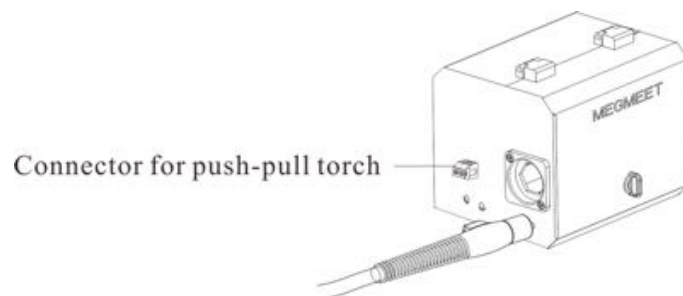

Figure 2-4 Robotic welding torch connection

Manual welding torch connection is shown in Figure 2-5.

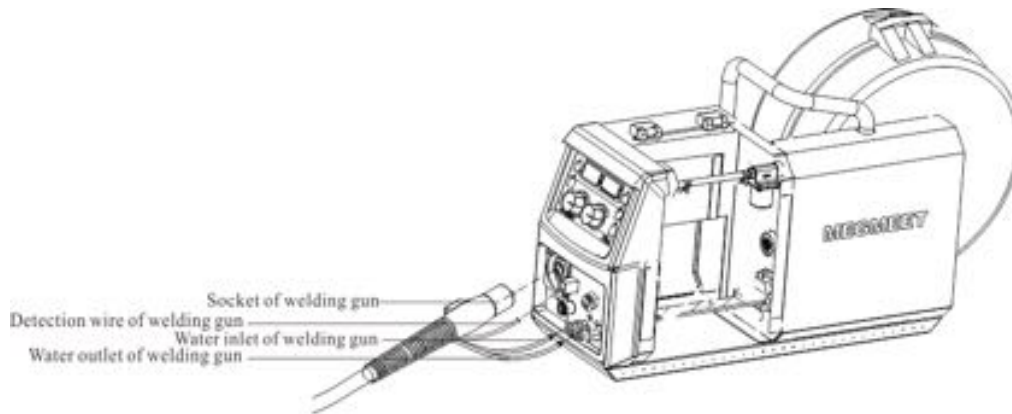

Figure 2-5 Manual welding torch connection

Welding torch connection for an light-weight manual wire-feeder is shown in Figure 2-6.

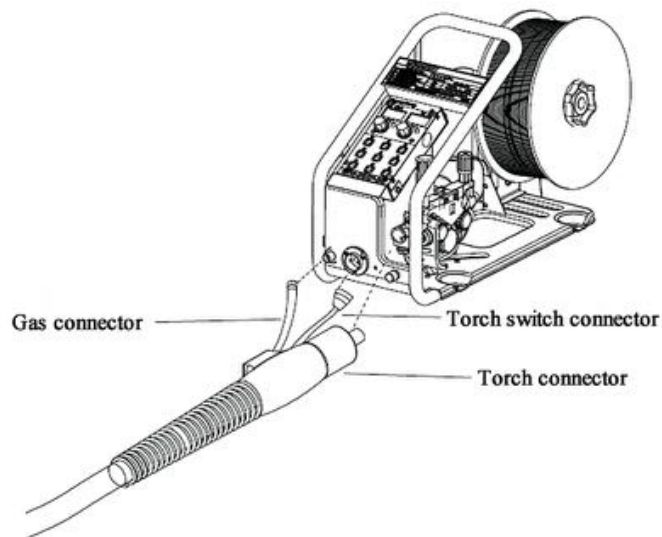

Figure 2-6 Welding torch connection for an light-weight manual wire-feeder

2.5.4 Connection of the push-pull torch

Steps:

Connecting the electric motor for the pushing-pulling wire welding torch to the pushing-pulling wire port on the wire-feeder, the left terminal of the port is “-”, and the right one is “+”.

The pushing-pulling wire ports of a robotic wire-feeder is shown in Figure 2-7.

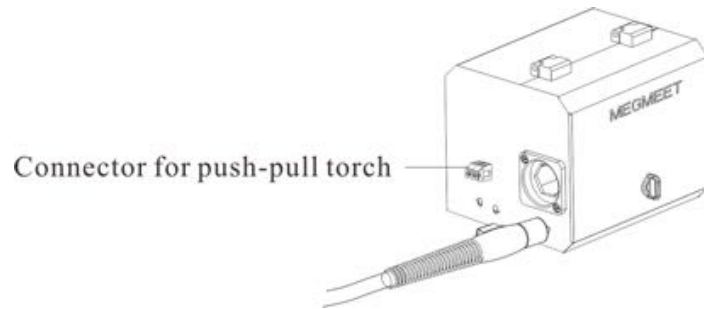

Figure 2-7 The pushing-pulling wire ports of a robotic wire-feeder

The pushing-pulling wire ports of a manual wire-feeder is shown in Figure 2-8.

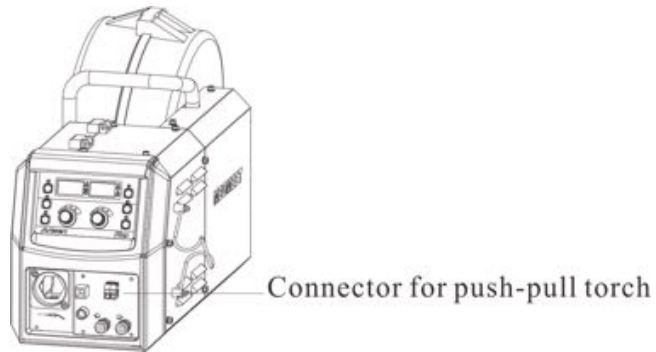

Figure 2-8 The pushing-pulling wire ports of a manual wire-feeder

2.5.5 Connection of the ground cable

Steps:

Fix one end of the ground cable to the output terminal of negative electrode; another end to the working piece, as shown in Figure 2-9.

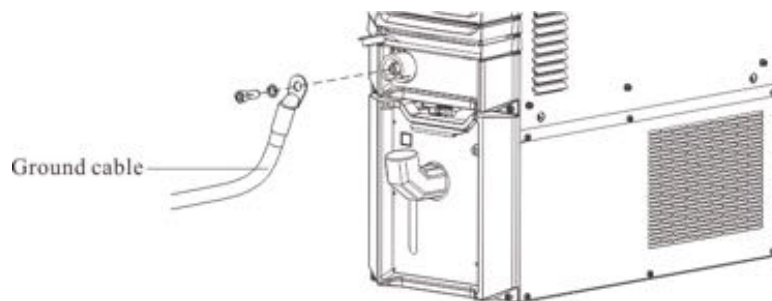

Figure 2-9 Working piece side positive output cable connection

2.5.6 Connection of the voltage feedback cable

Notes

When connect the feedback cable for welding, the following items should be strictly followed; otherwise the spatter would increase.

1. The ground cable should be connected to the welding position as closely as possible;
2. The ground cable and the welding output cable should be separated as further as possible (the space should be at least 100 mm or more);
3. When using an external positioning equipment, the voltage feedback cable should be connected to the screws on the fixing cover of the base of the external positioning equipment.

When the voltage feedback cable is connected to the welding power source side, then it is used for the welding power source side inspection; when the voltage feedback cable is connected to the wire-feeder side, it is used for the wire-feeder side inspection. (we recommend that the voltage feedback cable connect to the wire-feeder side.)

Connect the voltage feedback cable to the welding power source side.

Steps:

Fix one end of the voltage feedback cable to the terminal of the voltage feedback cable , and other end to the working piece, then the welding power source side connection of the voltage feedback cable is completed, as shown in Figure 2-10.

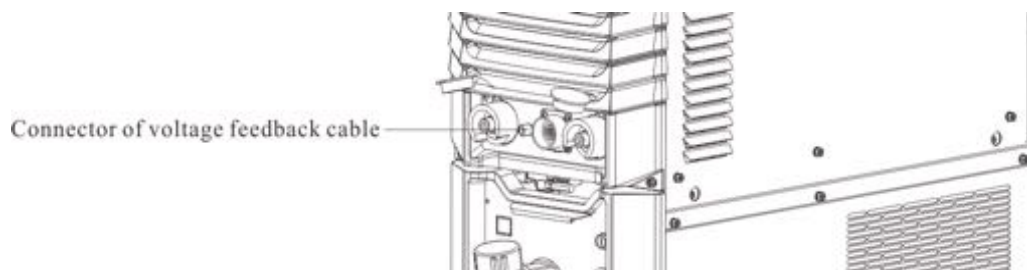

Figure 2-10 The welding power source side connection of the voltage feedback cable

Connect the voltage feedback cable to the wire-feeder side

Steps:

Fix one end of the voltage feedback cable to the terminal of the voltage feedback cable , and other end to the working piece, then the wire-feeder side connection of the voltage feedback cable is completed.

Robotic wire-feeder side connection of the voltage feedback cable is shown in Figure 2-11.

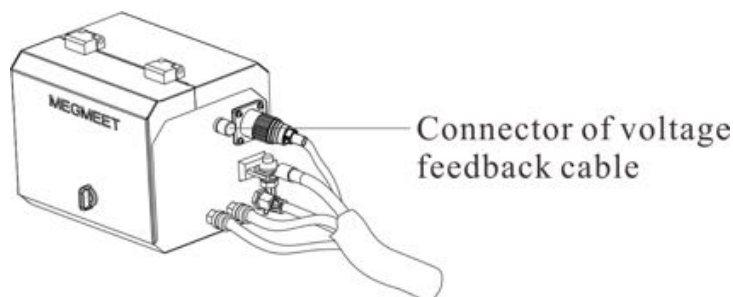

Figure 2-11 The robotic wire-feeder side connection of the voltage feedback cable

Enclosed wire-feeder side connection of the voltage feedback cable is shown in Figure 2-12.

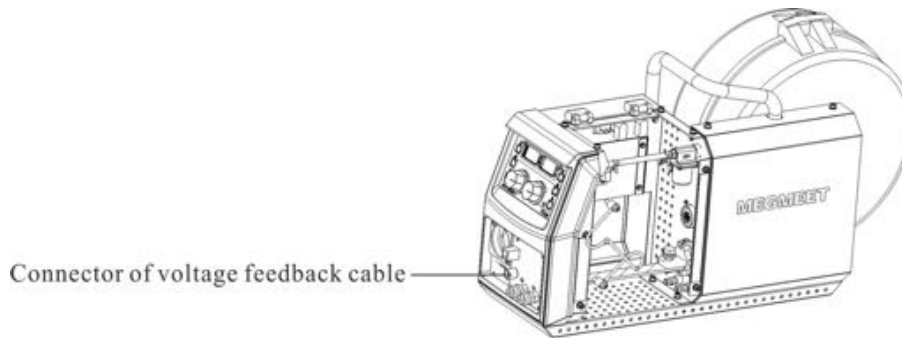

Figure 2-12 The standard manual wire-feeder side connection of the voltage feedback cable

Light-weight manual wire-feeder side connection of the voltage feedback cable is shown in Figure 2-13.

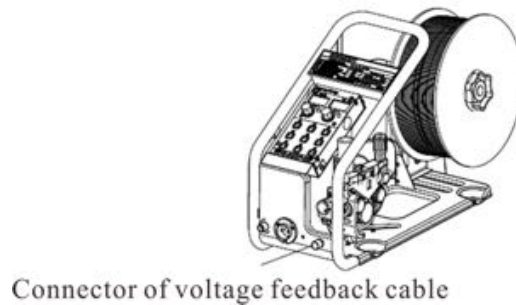

Figure 2-13 The light-weight manual wire-feeder side connection of the voltage feedback cable

voltage feedback cable connection for single-station or multi-station welding

When single-station or multi-station welding is to be done, the voltage feedback cable should be connected to the farthest part to the welding power source, as shown in Figure 2-14.

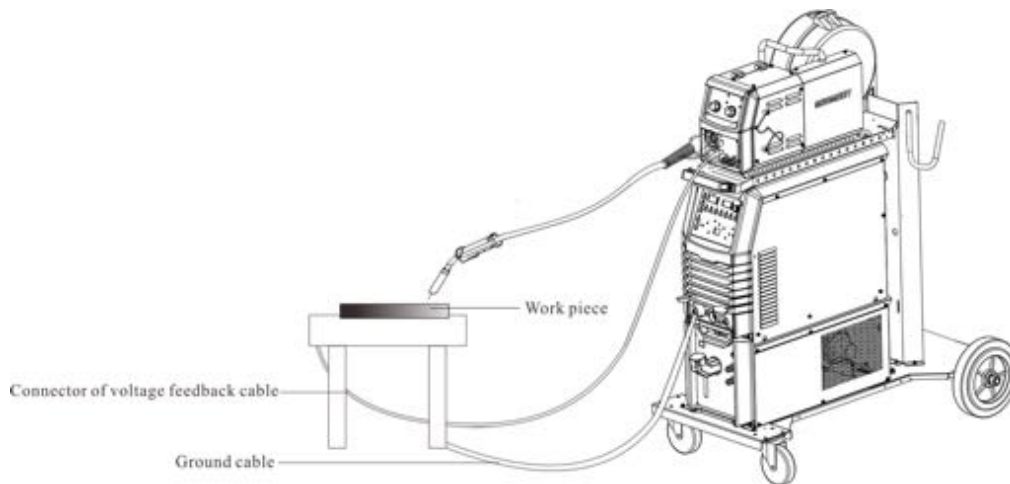

Figure 2-14 Connection of the ground cable and the voltage feedback cable for a single welding power source

voltage feedback cable connection for two welding power sources or more

When two welding power sources or more are used for welding, all the individual ground cables should be connected to the vicinity of the working piece, the voltage feedback cable should be connected in a way that can keep it away from the welding current path, and the distance between the welding output cable and the voltage feedback cable should be at least 100 mm or more. The connection is shown in Figure 2-15.

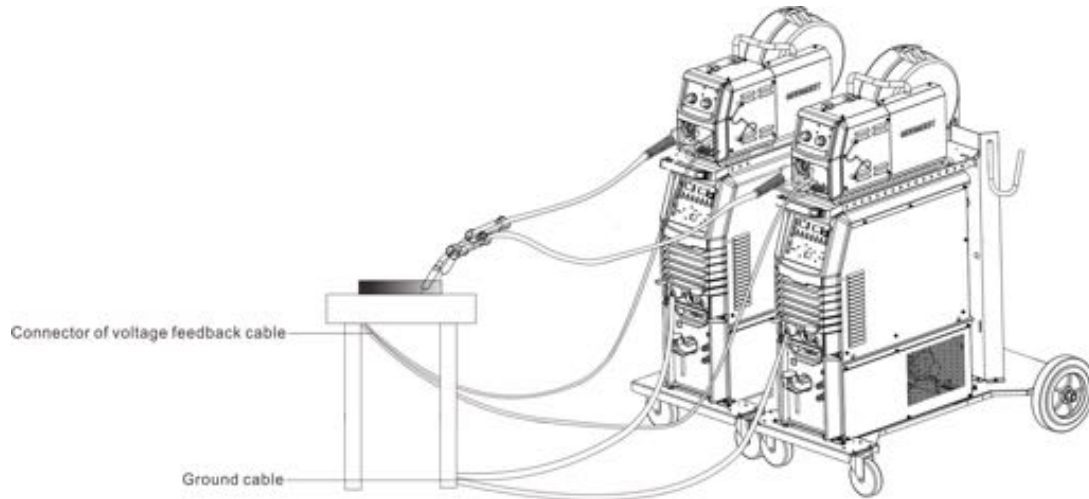

Figure 2-15 Connection of the ground cable and the voltage feedback cable for two welding power sources or more

2.5.7 Connection of the shield gas

Steps:

Connect both side of the gas hose to the fixing plate of the wire-feeder and the gas connector respectively. Tightening the gas hose clamp for both side to finish the gas hose connection.

Gas hose connection for a robotic wire-feeder is shown in Figure 2-17.

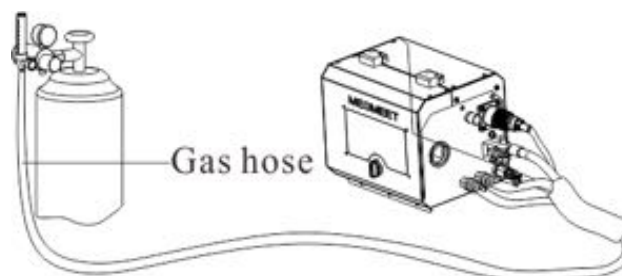

Figure 2-16 Gas hose connection for a robotic wire-feeder

Gas hose connection for an standard manual wire-feeder is shown in Figure 2-18.

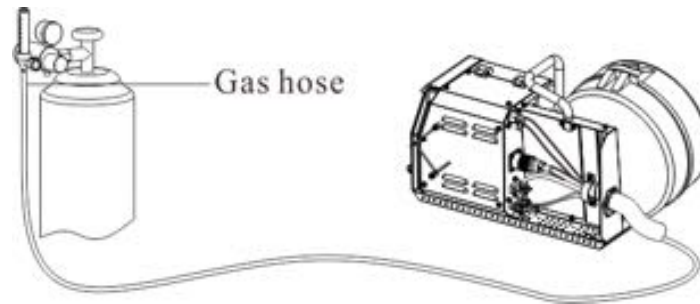

Figure 2-17 Gas hose connection for an standard manual wire-feeder

Gas hose connection for an light-weight manual wire-feeder is shown in Figure 2-19.

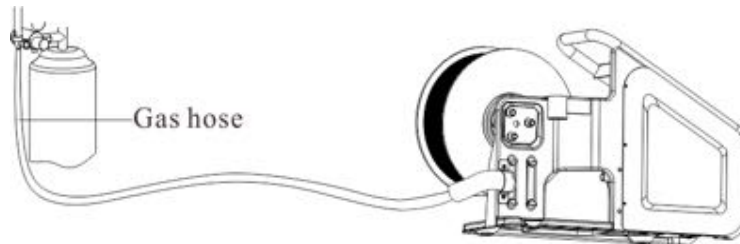

Figure 2-18 Gas hose connection for an light-weight manual wire-feeder

Notes

1. Using a heating pressure reducer for CO₂ when using CO₂ as protective gas.
2. The hose connection for both the wire-feeder side and the gas instrument side should be tightened properly; otherwise there is a risk of gas leakage.

2.5.8 Connection of the water cooler

Water tank power supply connection

Water tank power supply connection is shown in Figure 2-19.

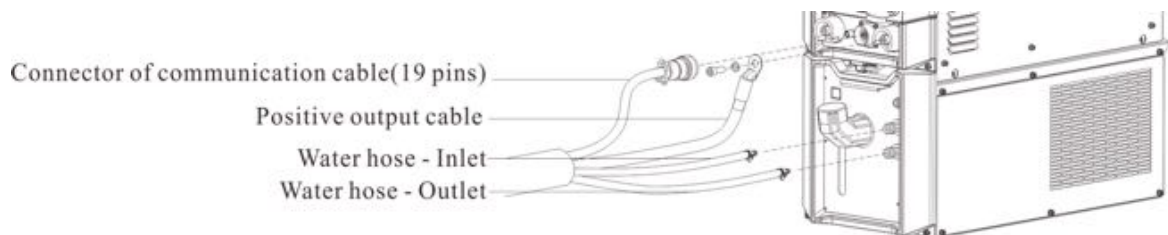

Figure 2-19 Schematic diagram of water tank power supply connection

Water tank pipe connection

Steps:

Plug the inlet water hose and outlet water hose into the water tank inlet water hose and outlet water hose respectively, as shown in Figure 2-19.

Warning about safety

1. The plug power supply for the water tank is of a high voltage of 380V AC, the welding power source should be turned off before wired; otherwise there is a risk of electric shock.
2. To use the water tank, the water-cooling function should be activated (P03 being at ON status, with OFF as a default status), and a self inspection for the water tank should be done on the panel before its normal use.
3. There is no a water flow inspection device for some water tanks, in this situation the user needed to set the P09 program parameter to OFF status (with On as a default status) and save it.
4. The dedicated antifreeze for the water tank should be used when the ambient working temperature is lower than 10°C; otherwise the water tank may be damaged.

2.5.9 Connection of input power cable (380V AC)

1. The three-phase input cable is of a standard configuration of 4.5m, without any special phase sequence requirement for the three-phase cable;
2. The three-phase cable is of 3+PE (yellow green), ensure the PE wire is reliably earthed before the machine power on;
3. The connection for the three-phase cable is shown in Figure 2-20.

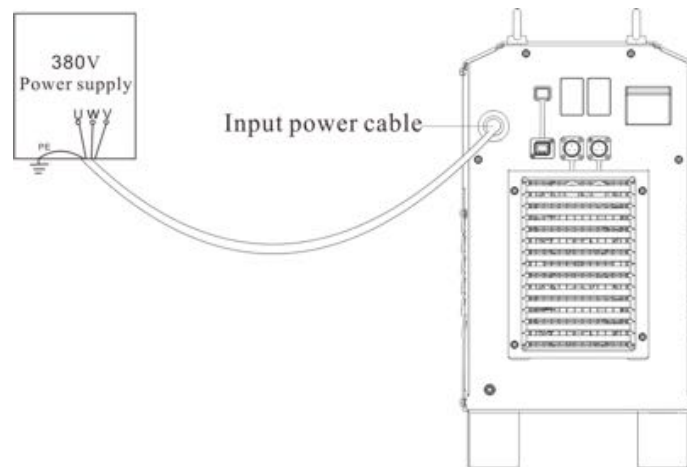
**Figure 2-20 Connection for the welding power source input side cable**

Chapter 3 Functions and operation

3.1 Setup panel

Panel function description for the welding power source is shown in Figure 3-1.

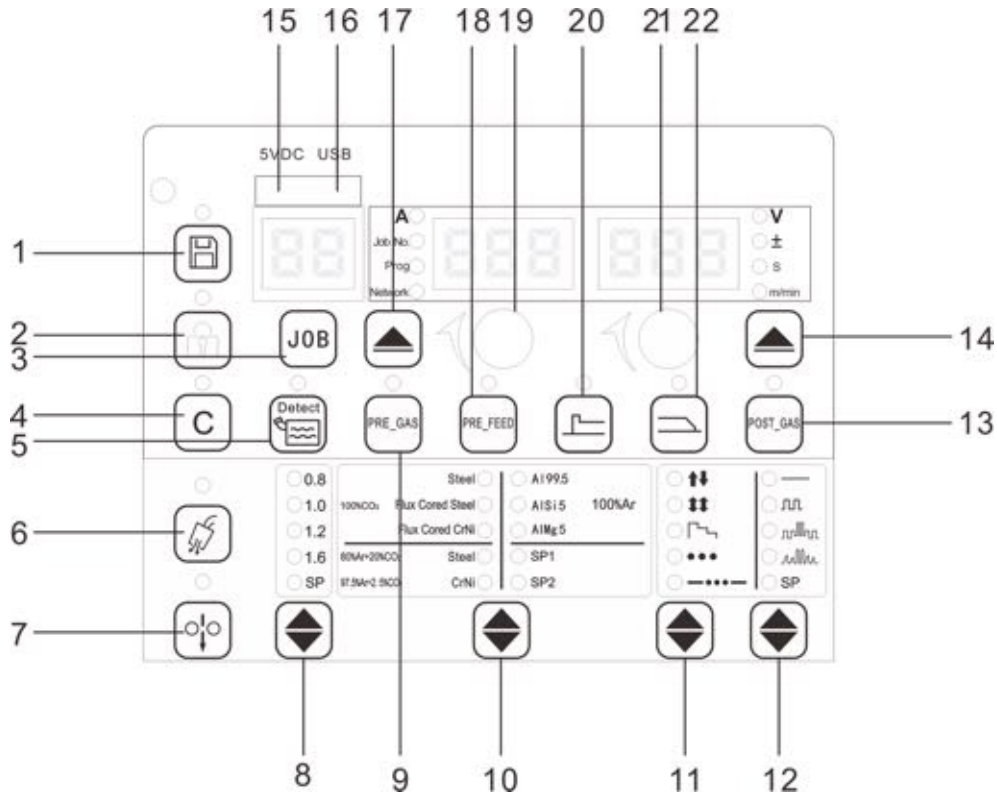

Figure 3-1 Panel of the welding power source

Table 3-1 Panel function description of the welding power source

No.	Name	Description of various functional keys
1	Save	To Save the current welding parameters.
2	Lock	To lock the current panel operations.
3	JOB	Activate to choose the JOB number.
4	Clear	To clear the error display on the panel.
5	Water flow inspection	For the water path inspection after the internal menu activates the water cooling function..
6	Gas inspection	To check if there is protective gas.
7	Inching feeding	Feed the wire to the top of welding torch under the non-welding condition..
8	Wire diameter	To choose different wire diameters; SP means customized wire diameters.
9	Pre-gas	It is the gas protection setting before starting the welding.
10	Material selection	To choose different welding materials; SP means customized welding materials.
11*	Welding control	To be sued to select different welding operation modes (2 steps, 4 steps, special 4 steps, inching welding and intermittent welding).
12*	Welding method	For selecting the different welding methods (direct current, single pulse and double pulses, DP synergy, SP customized welding method).
13	Post-gas	It is gas protection setting for the period after the welding is completed the welding.
14	select button	Switching key for the right LED display (V, ±, s, m/min.)
15	5V DC	To use 5V power bank as a direct power supply for the display panel.
16	USB flash disk port	To be used for welding power source firmware upgrading, support maximum

		100mA output.
17	select button	Switching key for the left LED display (A, channel, program, network).
18	Pre-feeding	To set the Pre-feeding before starting the welding.
19	Left knob	To adjust the parameters for the left LED display; when the JOB number is at an adjustable status, to be used to adjust the JOB number.
20	Parameters for Starting arc	To set the parameters for starting arc, such as wire feeding speed and Starting arc voltage.
21	Right knob	To adjust the parameters for the right LED display.
22	Parameters for Crater fill	To set the parameters for Crater fill, such as the wire feeding speed at Crater fill, the voltage at Crater fill and the like.

Notes

11*: Artsen Plus welding control: (2 steps, 4 steps, special 4 steps, inching welding and intermittent welding)

Artsen Pro welding control: (2 steps, 4 steps, special 4 steps, inching welding).

12*: Artsen Plus welding methods: (direct current, single pulse and double pulses, DP synergy, SP customized welding method)

Artsen Pro welding methods: (direct current, single pulse and double pulses, SP customized welding method).

Panel function description for the standard manual wire-feeder is shown in Figure 3-2.

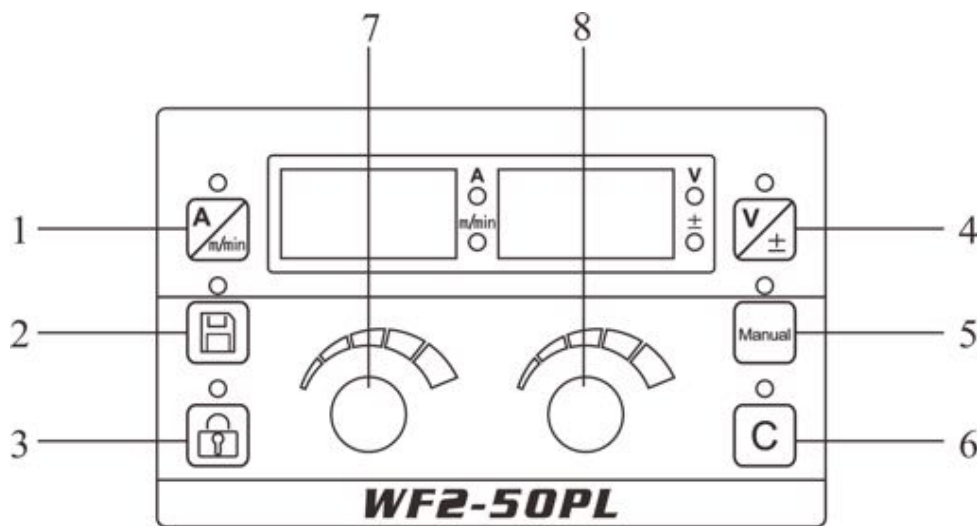

Figure 3-2 Panel of the standard manual wire-feeder

Table 3-2 Panel function description of the standard manual wire-feeder

No.	Name	Description of various functional keys
1	A / m/min.	To switch between the current display and the wire feeding speed display at the standby mode.
2	Save	To save the current welding parameters.
3	Lock	To lock the current panel operations.
4	V _±	To switch the arc length absolute value and the deviation at the standby mode.
5	Synergy mode/Manual mode	Manual mode can adjust the current and voltage respectively while synergy mode adjust the current and voltage by matching each other automatically.
6	Clear	To clear the error code display on the system.
7	Current adjustment knob	To adjust the current by the knob.

8	Voltage adjustment knob	To adjust the voltage by the knob.
---	-------------------------	------------------------------------

Panel function description for the light-weight manual wire-feeder is shown in Figure 3-3. The relevant parameters are shown in Table 3-3.

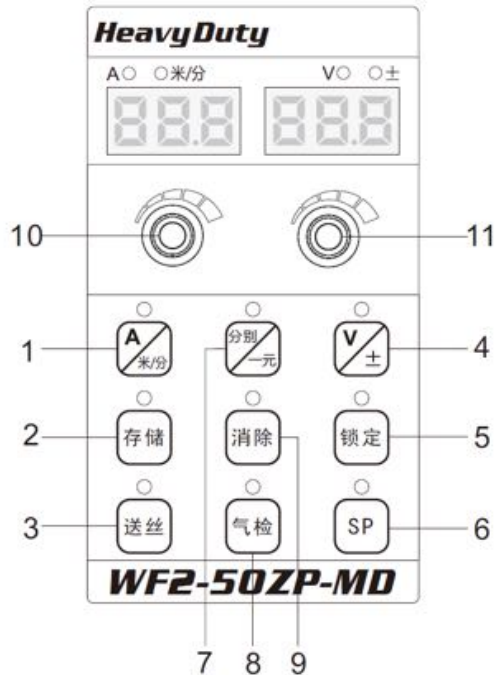

Figure 3-3 Panel of the light-weight manual wire-feeder

Table 3-2 Panel function description of the light-weight manual wire-feeder

No.	Name	Description of various functional keys
1	A / m/min.	To switch between the current display and the wire feeding speed display at the standby mode.
2	Save	To Save the current welding parameters.
3	Wire feeding	Under the non-welding condition, to feed the wire to the top of welding torch.
4	V_{\pm}	To switch the arc length absolute value and the deviation at the standby mode.
5	Lock	To lock the current panel operations.
6	SP	Reserved
7	Synergy mode/Manual mode	Manual mode can adjust the current and voltage respectively while synergy mode adjust the current and voltage by matching each other automatically.
8	Gas inspection	To check if there is protective gas.
9	Clear	To clear the error display on the screen.
10	Current adjustment knob	To adjust the current by the knob.
11	Voltage adjustment knob	To adjust the voltage by the knob.

3.2 LED display

Left LED display are used to display “A”, “Channel”, “Program” and “Network”, and when switched, the relevant LED indicator will be lit up. Right LED display are used to display “V”, “ \pm ”, “s” and “m/min.”, and when switched the relevant LED indicator will be lit up. LED display is shown in Figure 3-4. Parameters display is shown in Table 3-4.

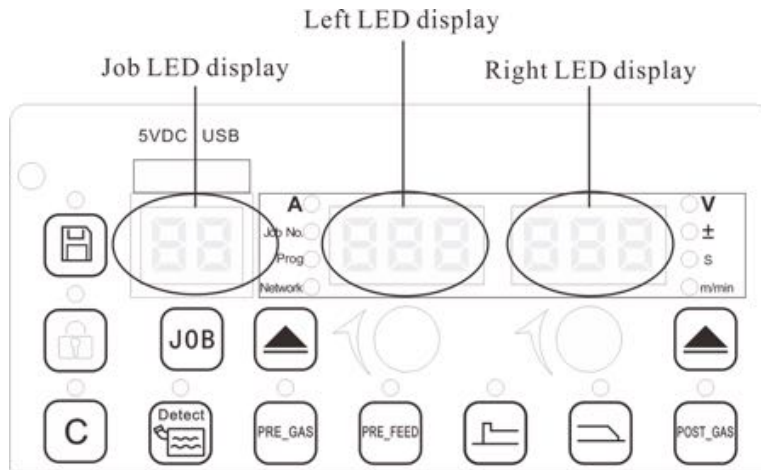

Figure 3-4 LED display display

Table 3-4 Welding parameters description for LED display

JOB LED display	Left LED display		Right LED display	
JOB number selected currently	Parameters	Welding parameters description	Parameters	Welding parameter description
	A	Current display	V	Voltage display
	Channel	Adjusting channel parameter	±	Voltage correction value display
	Program	Adjusting program parameter	s	Parameter time display
	Network	Adjusting network parameter	m/min.	Wire feeding speed display

3.3 Inching

Steps:

Press the “Inching feeding” key on the panel of the welding power source or that of the gr, only when keep pressing the inching button the wire will be fed.

1. Inching feeding of a robotic wire-feeder is shown in Figure 3-5.

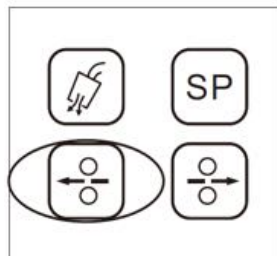

Figure 3-5 View of inching feeding of a robotic wire-feeder

2. Inching feeding of a manual wire-feeder is shown in Figure 3-6.

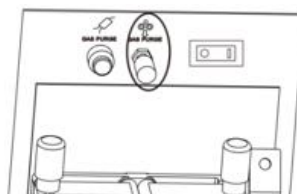

Figure 3-6 Inching feeding of a manual wire-feeder

3. Inching feeding on the panel of a welding power source is shown in Figure 3-7.

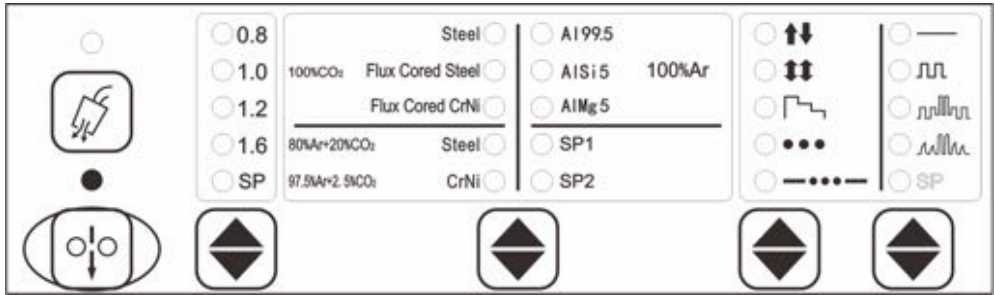

Figure 3-7 View of inching feeding on the panel of a welding power source

3.4 Gas check

Steps:

Press the “Gas check” key on the panel of the welding power source or the wire-feeder, the gas will be supplied for 30s. Pressing the button again to stop the gas supplied.

1. Gas check of a robotic wire-feeder is shown in Figure 3-8.

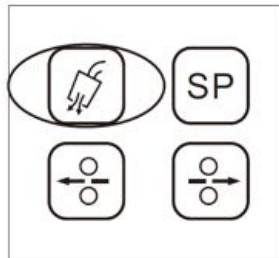

Figure 3-8 Gas check of a robotic wire-feeder

2. Gas check of a manual wire-feeder is shown in Figure 3-9.

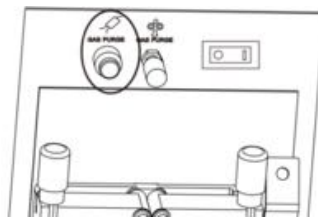

Figure 3-9 Gas check of a manual wire-feeder

3. Gas check of the panel of a welding power source is shown in Figure 3-10.

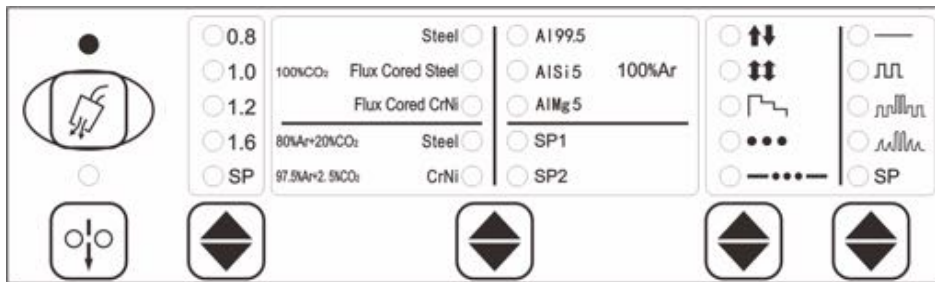

Figure 3-10 Gas check of the panel of a welding power source

3.5 Welding control

View of welding control is shown in figure 3-11.

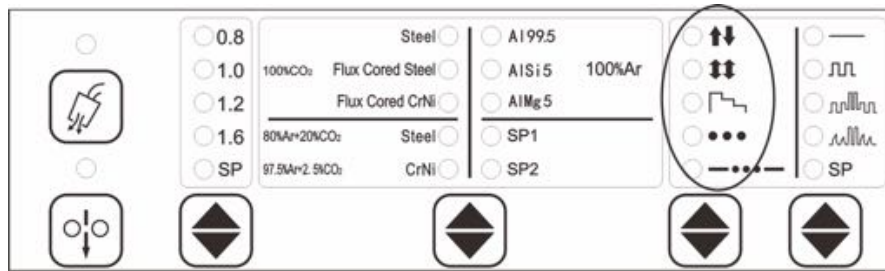

Figure 3-11 Welding control

3.5.1 2 steps

Pressing the “Welding control” key to switch to 2 steps mode, and the logic is shown in Figure 3-12.

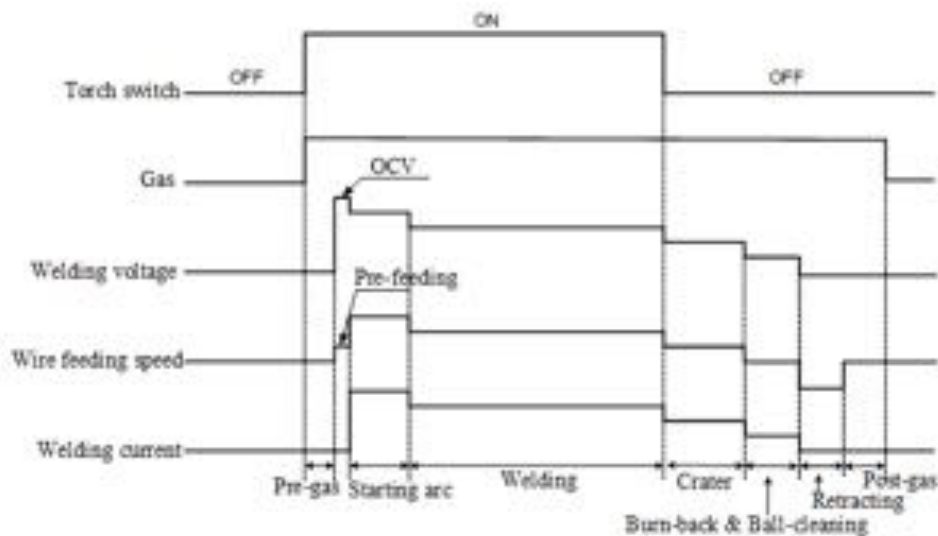

Figure 3-12 Logic diagram of 2 steps

Steps:

1. Set the time duration for Pre-gas (See chapter 3.8 for more details about pre-gas for JOB 1.).
2. Set the slow wire feeding speed rate and the wire advancing distance at Crater fill status (See chapter 3.9 for more details about slow wire feeding for JOB 2.).
3. Set the wire feeding speed rate for hot starting and the time duration for hot starting (See chapter 3.10 for more details about starting arc for JOB 4.Starting arc).
4. Set the wire feeding speed for hot filling arc crater and the time duration for hot filling arc crater (See chapter 3.11 for more details about hot cratering for JOB 5.).
5. Set the withdrawing speed rate for Crater fillcrater and the time duration of withdrawing for Crater fill (See chapter 3.12 for more details about crater for JOB 6.Crater fill).
6. Set the time duration for Post-gas (See chapter 3.13 for more details about post-gas for JOB 7.).
7. Set the voltage for burn-back (See chapter 3.7 for more details about burn-back for JOB 0).

3.5.2 Crater fill 4 steps

Press the “Welding control” key to switch to 4 steps mode, and the logic is shown in Figure 3-13.

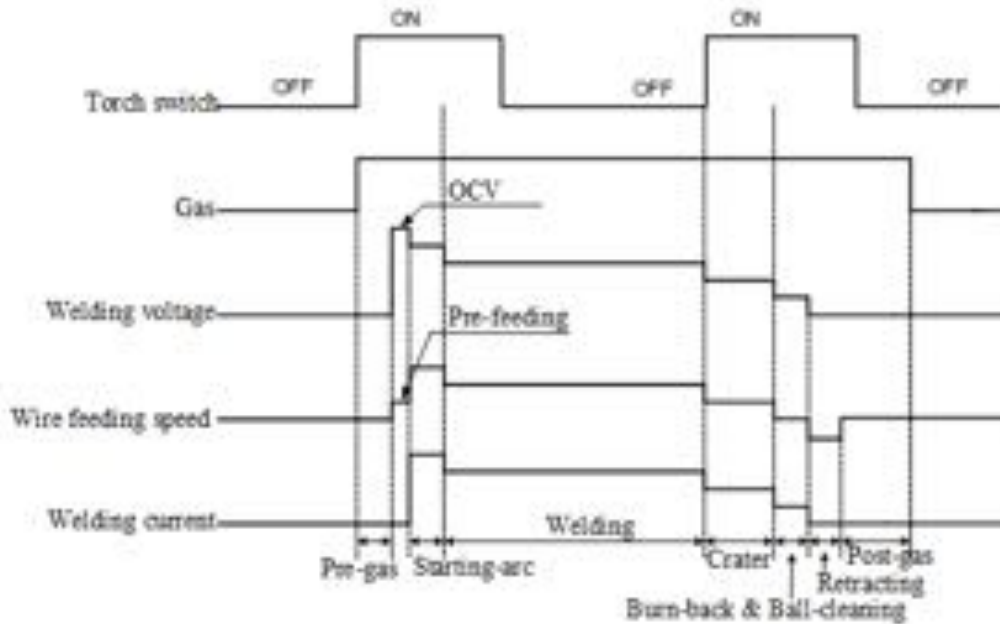

Figure 3-13 Logic diagram of 4 steps

Steps:

1. Set the time duration for Pre-gas (See chapter 3.8 for more details about pre-gas for JOB 1.).
2. Set the slow wire feeding speed rate and the wire advancing distance at Crater fill status (See chapter 3.9 for more details about slow wire feeding for JOB 2).
3. Set the wire feeding speed rate for hot starting and the time duration for hot starting (See chapter 3.10 for more details about starting arc for JOB 4 Starting arc).
4. Set the wire feeding speed for hot filling arc crater and the time duration for hot filling arc crater (See chapter 3.11 for more details about hot cratering for JOB 5.).
5. Set the withdrawing speed rate for Crater fill and the time duration of withdrawing for Crater fill (See chapter 3.12 for more details about crater for JOB 6Crater fill).
6. Set the time duration for Post-gas (See chapter 3.13 for more details about post-gas for JOB 5).
7. Set the voltage for craterburn-back (See chapter 3.7 for more details about burn-back for JOB 0).

3.5.3 Special 4 steps

Press the “Welding control” key to switch to special 4 steps mode, and the logic is shown in Figure 3-14.

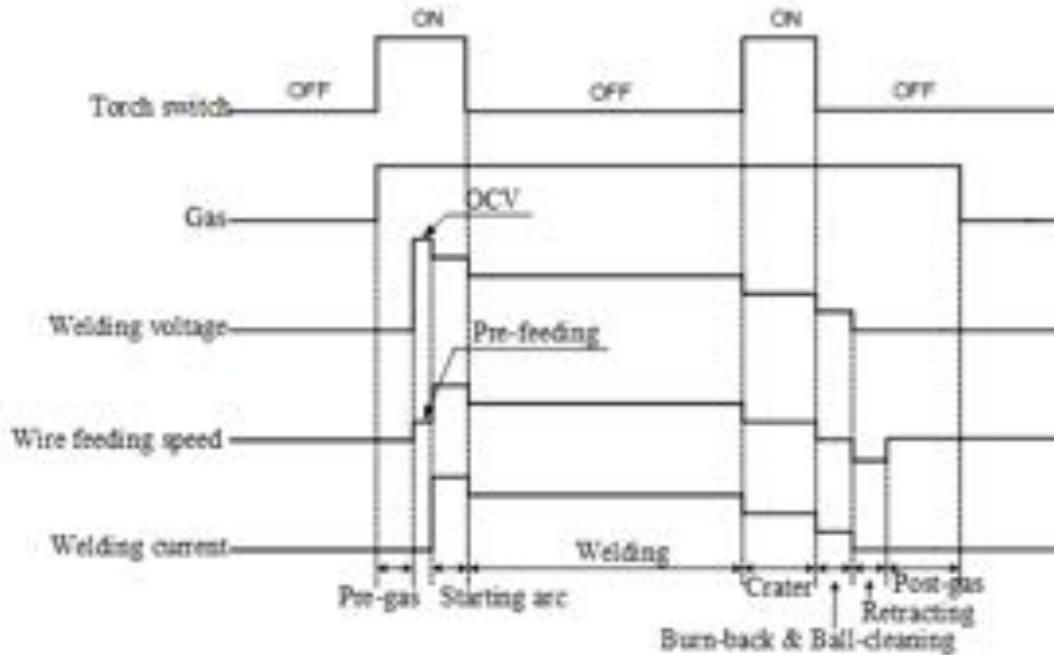

Figure 3-14 Logic diagram of special 4 steps

Steps:

1. Set the time duration for Pre-gas (See chapter 3.8 for more details about pre-gas for JOB 1).
2. Set the slow wire feeding speed rate and the wire advancing distance at Crater fill status (See chapter 3.9 for more details about slow wire feeding for JOB 2).
3. Set the wire feeding speed rate for hot starting and the time duration for hot starting (See chapter 3.10 for more details about starting arc for JOB 4).
4. Set the wire feeding speed for hot filling arc crater and the time duration for hot filling arc crater (See chapter 3.11 for more details about hot cratering for JOB 5).
5. Set the withdrawing speed rate for Crater fill and the time duration of withdrawing for Crater fill (See chapter 3.12 for more details about crater for JOB 6).
6. Set the time duration for Post-gas (See chapter 3.13 for more details about post-gas for JOB 7).
7. Set the voltage for burn-back (See chapter 3.7 for more details about burn-back for JOB 0).

3.5.4 Spot welding

Press the “Welding control” key to switch to spot welding mode, and the logic is shown in

Figure 3-15.

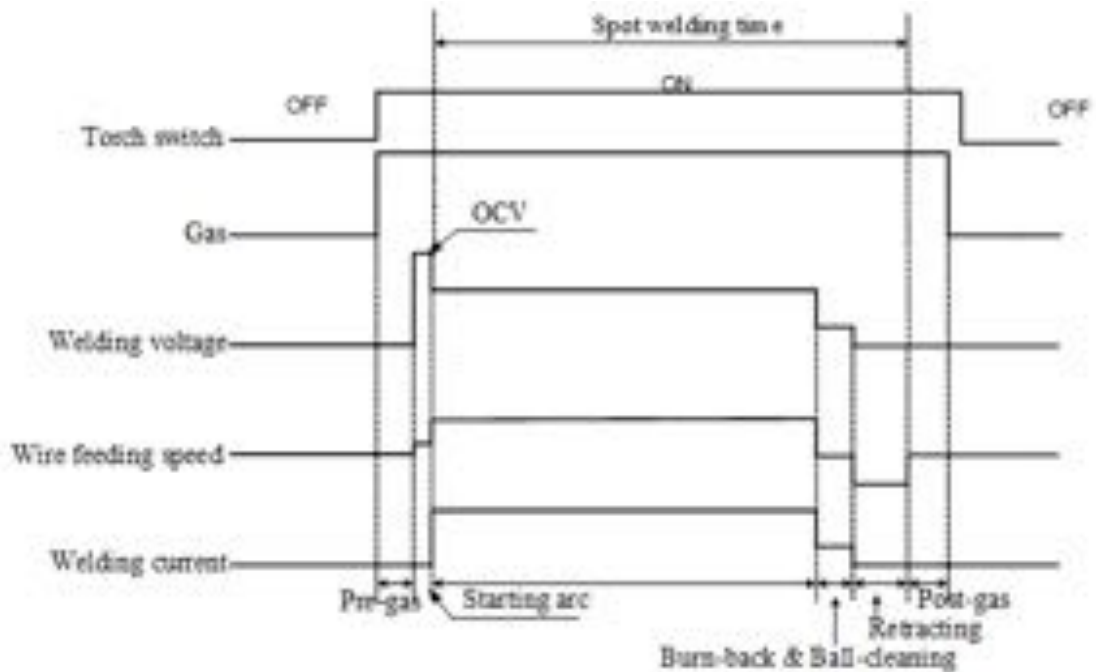

Figure 3-15 Logic diagram of spot welding

Steps:

8. Set the time duration for Pre-gas (See chapter 3.8 for more details about pre-gas for JOB 1.).
9. Set the slow wire feeding speed rate and the wire advancing distance at Crater fill status (See chapter 3.9 for more details about slow wire feeding for JOB 2).
10. Set the wire feeding speed rate for hot starting and the time duration for hot starting (See chapter 3.10 for more details about starting arc for JOB 4).
11. Set the wire feeding speed for hot filling arc crater and the time duration for hot filling arc crater (See chapter 3.11 for more details about hot cratering for JOB 5.).
12. Set the withdrawing speed rate for Crater fill and the time duration of withdrawing for Crater fill (See chapter 3.12 for more details about crater for JOB 6).
13. Set the time duration for Post-gas (See chapter 3.13 for more details about post-gas for JOB 5).
14. Set the voltage for burn-back (See chapter 3.7 for more details about burn-back for JOB 0).

3.5.5 Intermittent welding

The logic is shown in figure 3-16.

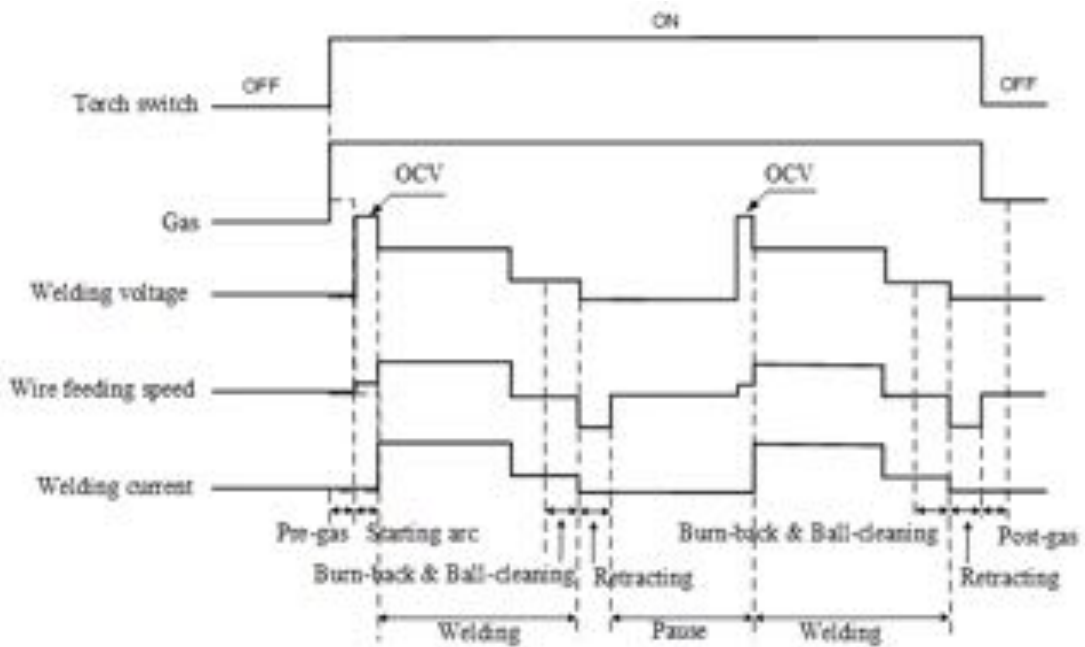

Figure 3-16 Logic diagram of intermittent welding

Steps:

15. Set the time duration for Pre-gas (See chapter 3.8 for more details about pre-gas for JOB 1.).
16. Set the slow wire feeding speed rate and the wire advancing distance at Crater fill status (See chapter 3.9 for more details about slow wire feeding for JOB 2).
17. Set the wire feeding speed rate for hot starting and the time duration for hot starting (See chapter 3.10 for more details about starting arc for JOB 4).
18. Set the wire feeding speed for hot filling arc crater and the time duration for hot filling arc crater (See chapter 3.11 for more details about hot cratering for JOB 5.).
19. Set the withdrawing speed rate for Crater fill and the time duration of withdrawing for Crater fill (See chapter 3.12 for more details about crater for JOB 6).
20. Set the time duration for Post-gas (See chapter 3.13 for more details about post-gas for JOB 5).
21. Set the voltage for burn-back (See chapter 3.7 for more details about burn-back for JOB 0).

3.6 Water flow inspection

Function inspection for water cooling cycle

Steps:

1. Turn to P03 and select ON to activate the water cooler after finishing the connection for the water-cooling device. (OFF as a default);

2. Pressing the “Water flow inspection” button, then the indicator for water flow inspection will be turned on. The water inspection will finish automatically at the same time, and the water cooling is setting successfully.

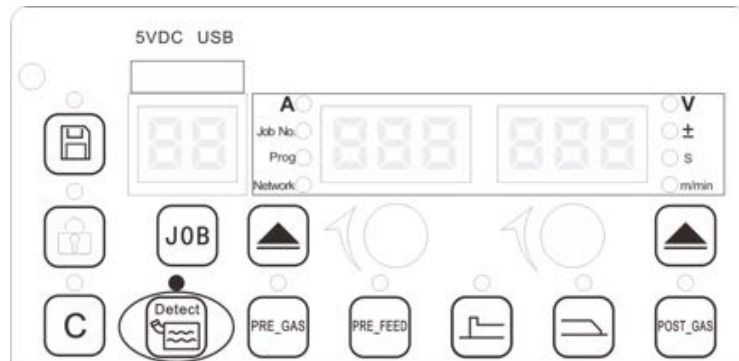

Figure 3-17 Setting view of water flow inspection

Notes

1. Activate the water cooling function to avoid the torch being damage if the welding machine equipped with a water tank and water-cooling torch.
2. The water cooler starts running with the welding process together while it stops after the welding process finishes for 2 minutes.
3. When the setting is completed, click “Save” to save the relevant parameters.

3.7 Burn-Back

Steps:

1. Pressing the JOB button and choose JOB 0 by turning the left knob. Then pressing the JOB button again to confirm the choice, and there will be the view for burn-back as shown in Figure 3-18.

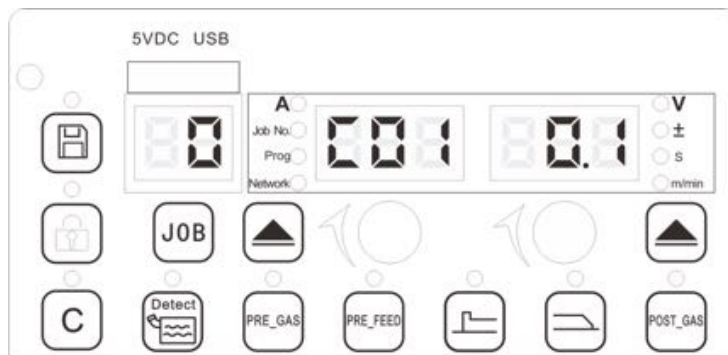

Figure 3-18 Burn-back setting

2. Turning the left knob to change the channel and turning the right knob to set the parameter. The corresponding parameter for channel number are shown in Table 3-5.

Table 3-5 List of the burn-back parameters

CHANNEL	DESCRIPTION FOR CHANNEL	ANNOTATION	DEFAULT VALUE
C01	Time duration	Setting the burn-back time/ Setting the interval time for intermittent welding.	0.1

C02~C04	Reserved	/	/
C05	The arc length factor for main wire feeding speed	To set the voltage for burn-back	-30
C06	The slope factor for main wire feeding speed	Hidden at the user mode	7
C07~C10	Reserved	/	/
C11	Direct current arc characteristic factor 1	Hidden at the user mode	0
C12	Direct current arc characteristic factor 2	Hidden at the user mode	0
C13	Slope for short-circuit current	Hidden at the user mode	0
C14	Reserved	/	
C15	Sensitivity factor for low spatter	Hidden at the user mode	0
C16	Weld penetration adjustment factor - 7~+7	/	0
C17~C19	Reserved	/	/
C20	Pulse peak current amplitude factor	Hidden at the user mode	0
C21	Pulse peak current time factor	Hidden at the user mode	0
C22	Rising slope factor of pulse current	Hidden at the user mode	0
C24	Pulse basic current factor	Hidden at the user mode	0
C25	High pulse frequency factor	Hidden at the user mode	0
C27	Pulse arc characteristic factor 2	Hidden at the user mode	0
C28	Pulse arc adjustment factor	Hidden at the user mode	0
C29	Pulse arc length adjustment factor	Hidden at the user mode	0
C30~C34	Reserved	/	/

3. Pressing the JOB key and turn the left knob to JOB No.10, then press the JOB key again to close the function and exit the setting view of burn-back welding parameters.

3.8 Pre-gas

Steps:

1. Press the “Pre-gas” button to activate the pre-gas function and wait for the indicator turns on, the view for Pre-gas is shown in Figure 3-19.

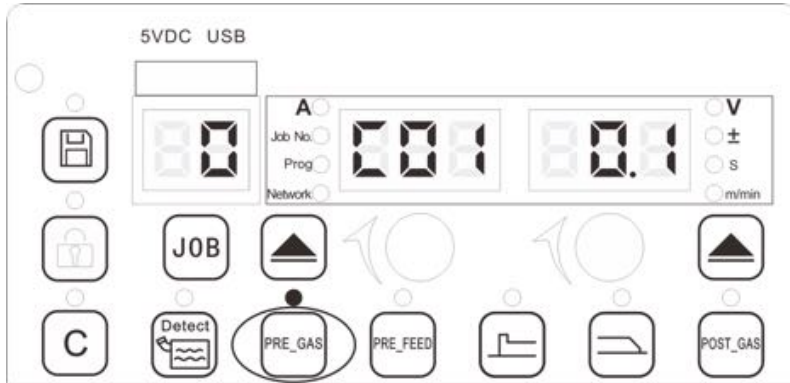

Figure 3-19 Parameters setting view of Pre-gas

2. Turn the “Left knob” to switch the channel and turn the “Right knob” to adjust the relevant parameters for pre-gas. The relevant parameters are shown in Table 3-6.

Table 3-6 List of the pre-gas parameters

CHANNEL	DESCRIPTION FOR CHANNEL	ANNOTATION	DEFAULT VALUE
C01	Time duration	To set the time duration of Pre-gas.	0.1
C02~C34	Reserved	/	/

3. Pressing the Pre-gas button again to exit the parameters setting.

3.9 Pre-feeding

Steps:

1. Press the “Pre-feed” button to activate the pre-gas function and wait for the indicator turns on, the view for Pre-feed is shown in Figure 3-20.

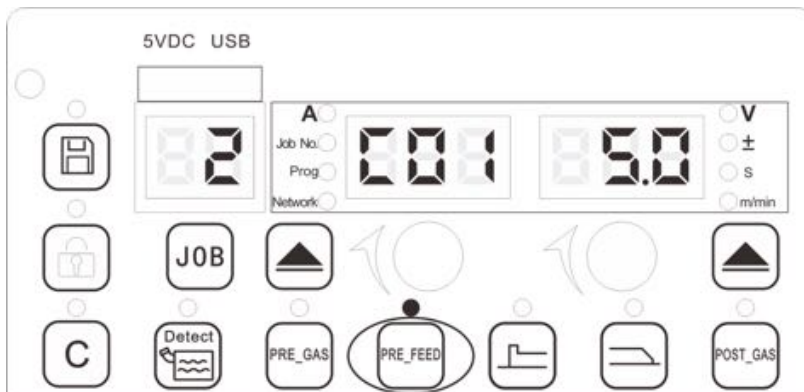

Figure 3-20 Parameters setting view of Pre-feeding

2. Turn the “Left knob” to switch the channel and turn the “Right knob” to adjust the channel number-relevant parameters of Pre-feeding. The relevant parameters are shown in Table 3-7.

Table 3-7 List for the Pre-feed parameters

CHANNEL	DESCRIPTION FOR CHANNEL	ANNOTATION	DEFAULT
---------	-------------------------	------------	---------

			VALUE
C01	Length	To set the wire advancing distance at the starting arc status	5.0, (unit: cm)
C02	Reserved	/	/
C03	Wire feeding speed	To set Pre-feeding speed at the Starting arc status	3.0 (unit: m/min)
C04	Reserved	/	/
C05	Arc length factor for main wire feeding speed	/	0
C06	Slope factor of main wire feeding speed	/	7
C07~C10	Reserved	/	/
C11	Direct current arc characteristic factor 1	Hidden at the user mode	0
C12	Direct current arc characteristic factor 2	Hidden at the user mode	7
C13	Slope factor of short-circuit current	Hidden at the user mode	0
C14	Reserved	/	/
C15	Sensitivity factor for low spatter	Hidden at the user mode	0
C16	Penetration adjustment factor -7~+7	/	0
C17~C19	Reserved	/	/
C20	Pulse peak current amplitude factor	Hidden at the user mode	0
C21	Pulse peak current time factor	Hidden at the user mode	0
C22	Rising slope factor of pulse current	Hidden at the user mode	0
C24	Pulse basic current factor	Hidden at the user mode	0
C25	High pulse frequency factor	Hidden at the user mode	0
C27	Pulse arc characteristic factor 2	Hidden at the user mode	0
C28	Pulse arc adjustment factor	Hidden at the user mode	0
C29	Pulse arc length adjustment factor	Hidden at the user mode	0
C30~C34	Reserved	/	/

3. Press the Pre-feeding key to turn the Pre-feeding indicator off, the function will be closed and exit the parameters setting view of Pre-feeding.

3.10 Starting arc

Steps:

1. Press the “starting arc” button to activate the starting arc function and wait for the indicator turns on, the view for starting arc is shown in Figure 3-21.

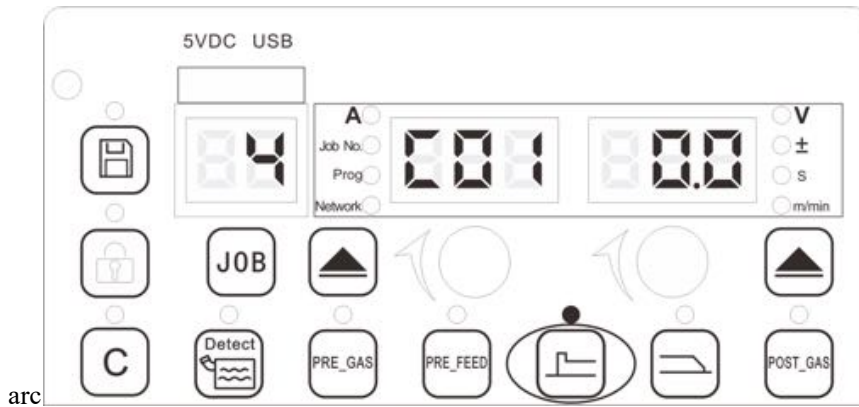

Figure 3-21 Setting view of starting arc parameters

2. “±” and “s” can be switched to view by the select button;
3. Turn the “Left knob” to switch the channel number parameters, and turn the “Right knob” to adjust the channel number-relevant starting arc parameters. The relevant parameters are shown in Table 3-8.

Table 3-8 List for the starting arc parameters

CHANNEL	DESCRIPTION FOR CHANNEL	ANNOTATION	DEFAULT VALUE
C01	Time duration	To set the time duration for hot starting arc	0
C02	Reserved	/	/
C03	Reserved	/	/
C04	Main wire feeding speed correction rate	The rate to normal welding JOB main wire feeding speed	100%
C05	Arc length factor for main wire feeding speed	/	0
C06	Slope factor of main wire feeding speed	/	0
C07~C10	Reserved	/	/
C11	Direct current arc characteristic factor 1	Hidden at the user mode	0
C12	Direct current arc characteristic factor 2	Hidden at the user mode	0
C13	Slope factor of short-circuit current	Hidden at the user mode	0
C14	Reserved	/	
C15	Sensitivity factor for low spatter	Hidden at the user mode	0
C16	Penetration adjustment factor -7~+7	/	0
C17~C19	Reserved	/	/
C20	Amplitude factor for pulse peak current	Hidden at the user mode	0
C21	Current time factor for pulse peak current	Hidden at the user mode	0
C22	Rising slope factor of pulse current	Hidden at the user mode	0
C25	High pulse frequency factor	Hidden at the user mode	0
C27	Pulse arc characteristic factor 2	Hidden at the user mode	0
C28	Pulse arc adjustment factor	Hidden at the user mode	0
C29	Pulse arc length adjustment factor	Hidden at the user mode	0

C30	Synergy frequency	Exclusive in some software	1.0
C31	Duty cycle for wire feeding speed of low-power section of double pulse	Exclusive in some software	0
C32	Slave wire feeding speed rate	Exclusive in some software	100
C33	Arc length factor for wire feeding speed of low-power section of double pulse	Exclusive in some software	0
C34	Slope factor for wire feeding speed of low-power section of double pulse	Exclusive in some software	7

4. Press the starting arc key again to exit the setting.

3.11 Crater

Steps:

1. Press the “crater” button to activate the starting arc function and wait for the indicator turns on, the view for crater is shown in Figure 3-22.

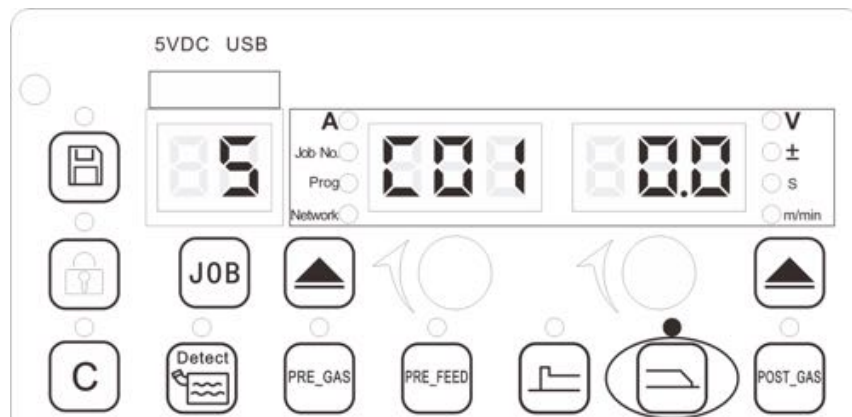

Figure 3-22 Setting view of crater parameters

2. “±” and “s” can be switched to view by Right cycle switching key;
 3. Turn the “Left knob” to switch the channel number parameters, and turn the “Right knob” to adjust the channel number-relevant crater parameters. The channel number parameters are shown in Table 3-9.

Table 3-9 List for the crater parameters

CHANNEL	DESCRIPTION FOR CHANNEL	ANNOTATION	DEFAULT VALUE
C01	JOB time duration	To set the time duration for cratering	0
C02~C03	Reserved	/	/
C04	correction rate for main wire feeding speed	The rate to normal welding JOB main wire feeding speed	100%
C05	Arc length factor for main wire feeding speed	/	0
C06	Slope factor of main wire feeding speed	/	0
C07~C10	Reserved	/	/

C11	Direct current arc characteristic factor 1	Hidden at the user mode	0
C12	Direct current arc characteristic factor 2	Hidden at the user mode	0
C13	Slope factor of short-circuit current	Hidden at the user mode	0
C14	Reserved	/	
C15	Sensitivity factor for low spatter	Hidden at the user mode	0
C16	Weld penetration adjustment factor -7~+7	/	0
C17~C19	Reserved	/	/
C20	Pulse peak current amplitude factor	Hidden at the user mode	0
C21	Pulse peak current time factor	Hidden at the user mode	0
C22	Rising slope factor of pulse current	Hidden at the user mode	0
C24	Pulse basic current factor	Hidden at the user mode	0
C25	High pulse frequency factor	Hidden at the user mode	0
C27	Pulse arc characteristic factor 2	Hidden at the user mode	0
C28	Pulse arc adjustment factor	Hidden at the user mode	0
C29	Pulse arc length adjustment factor	Hidden at the user mode	0
C30	Synergy frequency	Exclusive in some software	1.0
C31	Duty cycle for wire feeding speed of low-power section of double pulse	Exclusive in some software	0
C32	Wire feeding speed ratio of low-power section of double pulse	Exclusive in some software	100
C33	Arc length factor for wire feeding speed of low-power section of double pulse	Exclusive in some software	0
C34	Slope factor of wire feeding speed of low-power section of double pulse	Exclusive in some software	7

4. Press the crater button again to exit the setting view of crater.

3.12 Wire retract

Steps:

1. Press the JOB key and switch the left knob to JOB No.6, then press the “JOB” button again to confirm the choice, as shown in Figure 3-23.

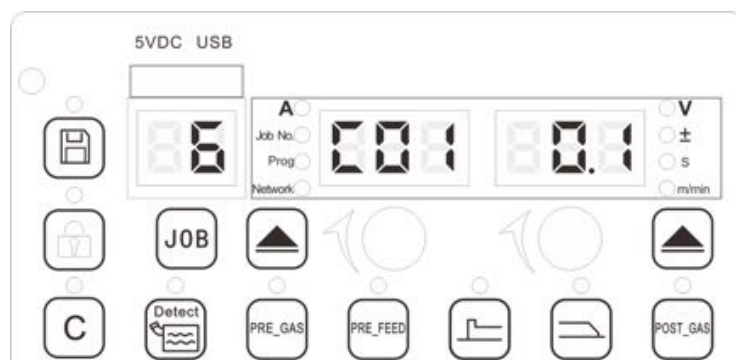

Figure 3-23 Setting view of withdrawing parameters

2. Turn the “Left knob” to switch the channel number parameters, and turn the “Right knob” to adjust the channel number-relevant withdrawing parameters. The channel number parameters are shown in Table 3-10.

Table 3-10 List for the wire retract parameters

CHANNEL	DESCRIPTION FOR CHANNEL	ANNOTATION	DEFAULT VALUE
C01	Time duration	To set the time duration of withdrawing for crater	0.04
C02	Reserved	/	/
C03	To set the withdrawing speed for crater	/	-9.8
C04~C34	Reserved	/	/

3. Press the JOB button again and turn the left knob to JOB 10. Pressing the JOB button again to confirm the choice, to close the function and exit the setting view of wire retract parameters.

3.13 Post-gas supply

Steps:

1. Press the “post-gas” button to activate the post-gas function and wait for the indicator turns on, the view for post-gas is shown in Figure 3-24.

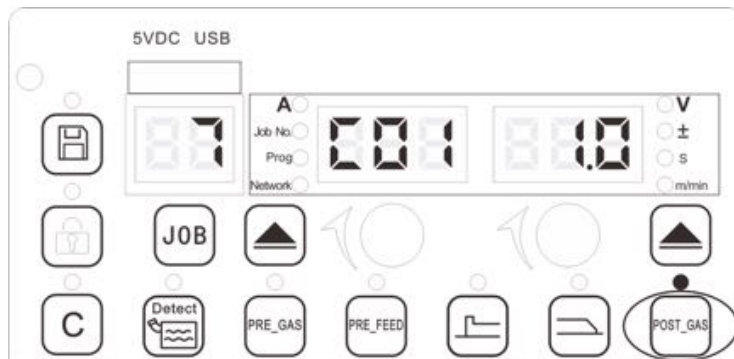

Figure 3-24 Parameters setting view of Post-gas

2. Turn the “Left knob” to switch the channel number parameters, and turn the “Right knob” to adjust the channel number-relevant parameters of Post-gas. The channel number parameters are shown in Table 3-11.

Table 3-11 List of parameters of Post-gas

CHANNEL	DESCRIPTION FOR CHANNEL	ANNOTATION	DEFAULT VALUE
C01	JOB time duration	To set the time duration of Post-gas	1.0
C02~C34	Reserved	/	/

3. Press the Post-gas key, then the indicator for Post-gas will be off, the function be closed and exit the setting view of Post-gas.

3.14 Inching

Steps:

1. Press the JOB key and switch the left knob to JOB No.9, then press the “JOB” button again to confirm the choice, as shown in Figure 3-23.

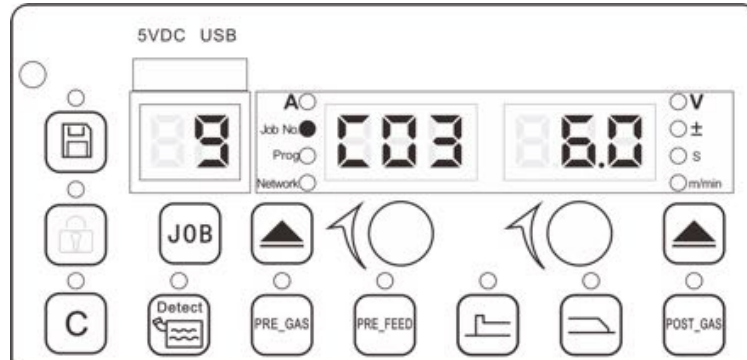

Figure 3-25 Setting view of inching feeding parameters

2. Turn the “Left knob” to switch the channel number parameters, and turn the “Right knob” to adjust the channel number-relevant inching feeding parameters. The channel number parameters are shown in Table 3-12.

Table 3-12 List of inching feeding parameters

CHANNEL	DESCRIPTION FOR CHANNEL	ANNOTATION	DEFAULT VALUE
C01~C02	Reserved	/	/
C03	Main wire feeding speed	/	6.0
C04~C05	Reserved	/	/
C06	Slope factor of main wire feeding speed	/	-3
C07~C34	Reserved	/	/

3. Press the JOB button again and turn the left knob to JOB 10, then pressing the JOB button again to confirm the choice and exit the setting view of wire inching parameters.

3.15 inching Save parameters

It is used to save the current panel parameters.

Steps:

Pressing the Save Button to save the setting, the indicator turns on when saving finish.

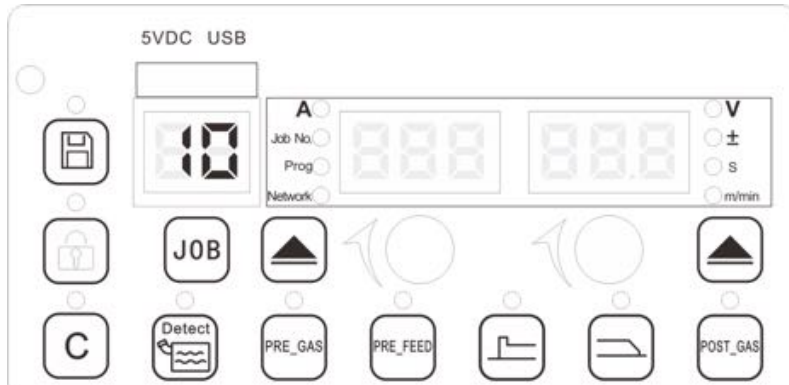

Figure 3-26 Setting view of Save

Notes

1. When setting is completed, save such setting before the welding power source is turned off; otherwise, the set parameters will not be saved.
2. Before switch to next channel upon one channel parameters setting completed, such setting should be saved.

3.16 Lock parameters

It is used to lock the current panel parameters.

Steps:

1. Pressing the Lock key, the indicator for Lock will be turned on, and the functional keys on the panel cannot be operated anymore;
2. Pressing the Lock key again, the indicator for Lock will be turned off, which means the panel can be operated again.

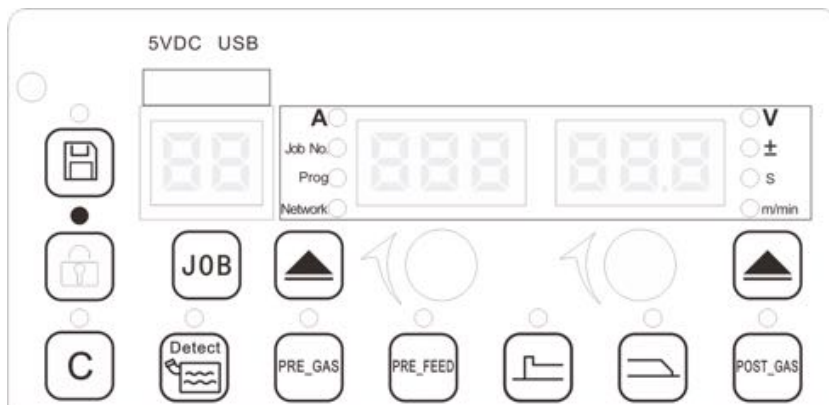

Figure 3-27 Setting view of Lock

3.17 Clear parameters

Steps:

1. Pressing the Clear key to clear the warnings that occur during the operation.
2. Only when all warnings are cleared, can the welding power source be normally used, and for the detailed operations, see **5.2 Failure code and solution for the welding power source**.

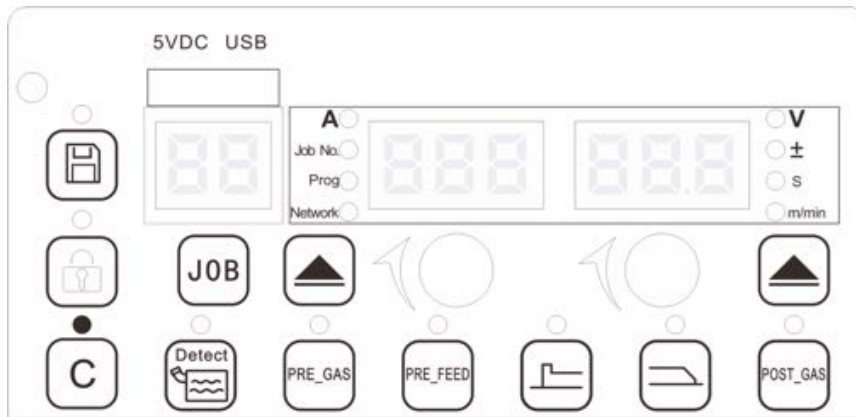

Figure 3-28 Setting view of Clear

3.18 Restore to factory settings and data

Steps:

Restore to factory settings

Simultaneously press the both select buttons on the panel of welding power source for 2 seconds, the welding power source is restored to the factory parameters settings. Please restart the welding power source after restoring to factory setting.

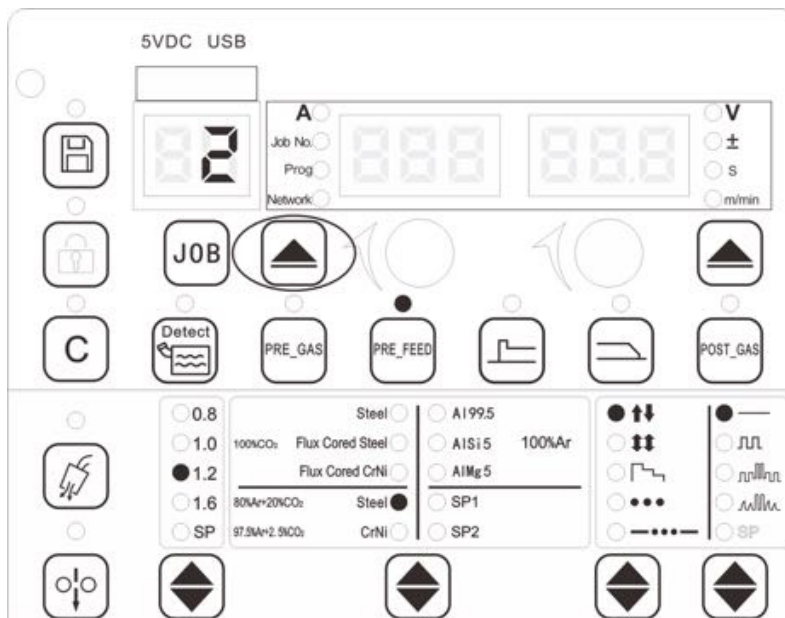

Figure 3-29 View of restore to factory settings of a welding power source

Restore to factory data

Simultaneously press the Clear button and the both select button on the panel of welding power source for 2 seconds, wait for continuous 5 seconds, The welding power source is restored to the factory data in another 5 seconds. Please restart the welding power source after restoring to factory data.

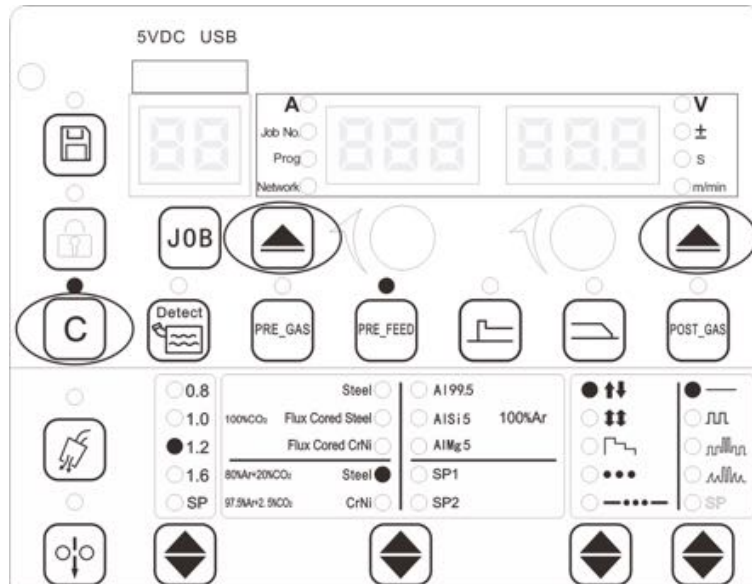

Figure 3-30 View of restore to factory data of a welding power source

Restore to factory settings for a wire-feeder

Simultaneously press the “A / m/min” and “V/±” keys on the panel of the wire-feeder for 2 seconds, wire-feeder, please restart the wire-feeder after restoring to factory.

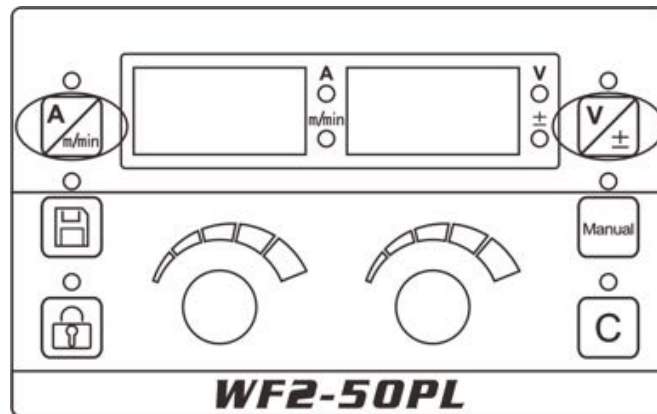

Figure 3-31 View of restore to factory settings for an standard manual wire-feeder

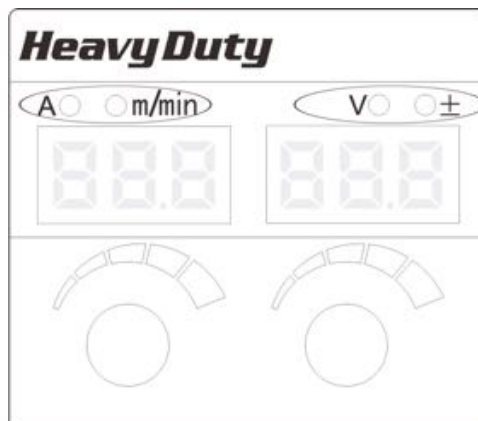

Figure 3-32 View of restore to factory settings for an light-weight manual wire-feeder

Notes

Only the systematic JOB parameters are restored in restore to factory settings, the setting for user's JOB parameters will not be cleared while both the systematic JOB parameters and the user's JOB parameters will be restored when restore to factory data.

3.19 Manually switching JOB number

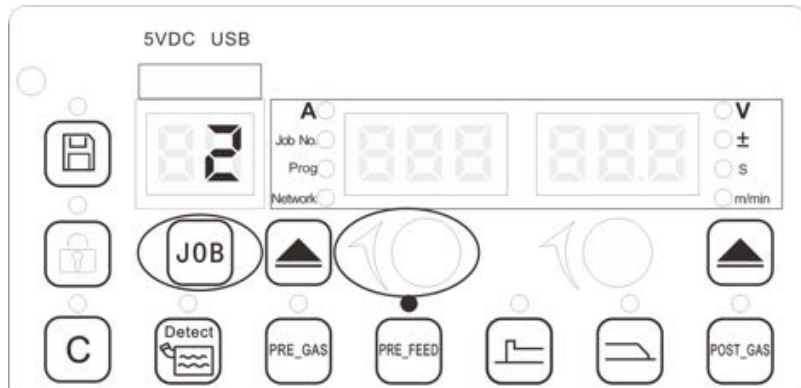

Figure 3-33 Setting view of manually switching JOB number

Steps:

1. Pressing the JOB button and the JOB number LED display will flash and indicates the current JOB number, then turn the “Left knob” to adjust to the relevant JOB number;
2. Press the “JOB” key again, then the JOB number will be selected, and the LED display will stop flashing.

Notes

- 1., The current flashing JOB number will be selected if the JOB number LED display flash for more than 5s without any operation, and the LED display will stop flashing.
2. Numbers of 0 -9 are systematic JOB numbers, while numbers of 10 -99 are the user's JOB numbers. Switching to the user's JOB number before welding; otherwise the welding power source give a warning of Err23.

3.20 Upgrading the firmware with a USB flash disk

3.20.1 Preparations

1. A USB flash disk with its storage capacity being no more than 32GB.
2. Copy the firmware files for upgrading the welding power source to the root directory of the USB flash disk.
3. One power bank (optional) with its output parameters being 5V~1A.

Notes

1. Before using the USB flash disk to upgrade the firmware of the welding power source, the welding power source should be turned off, and all external communication ports of the welding power source should be disconnected.
2. Do not substitute a mobile hard disk for a USB flash disk.

3.20.2 General upgrading mode

Steps

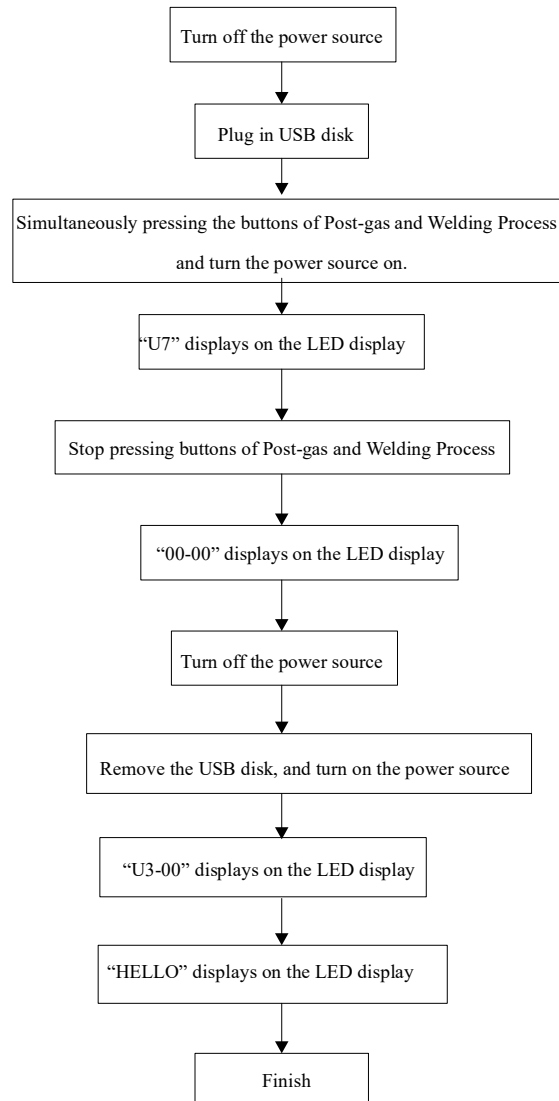

3.20.3 Upgrading mode with a power bank

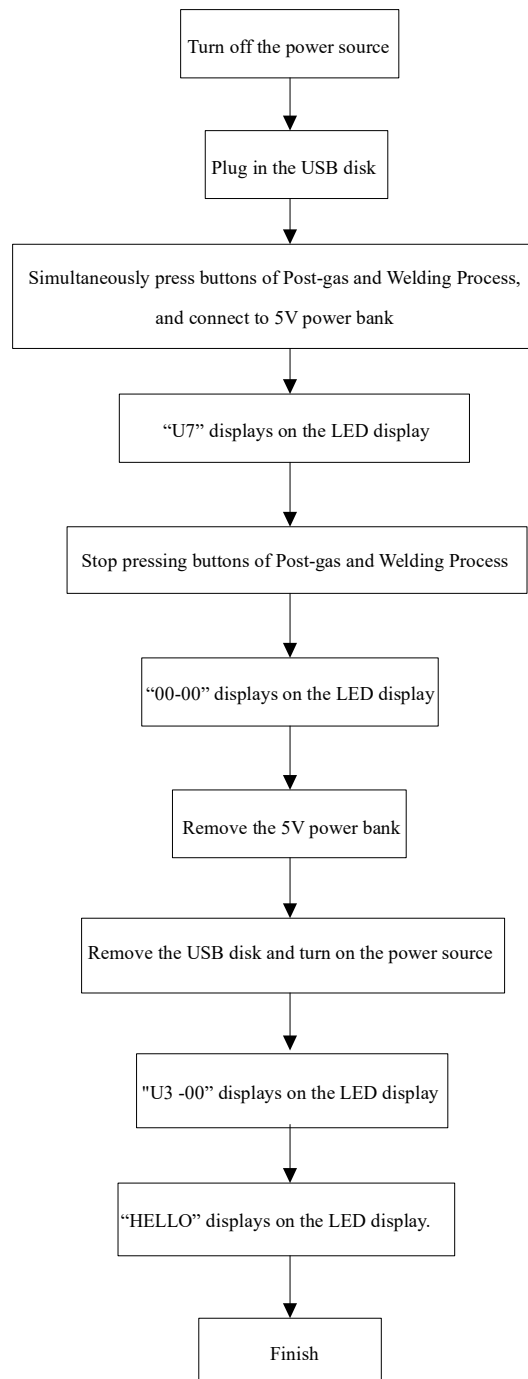

3.20.4 Communication Box firmware upgrade

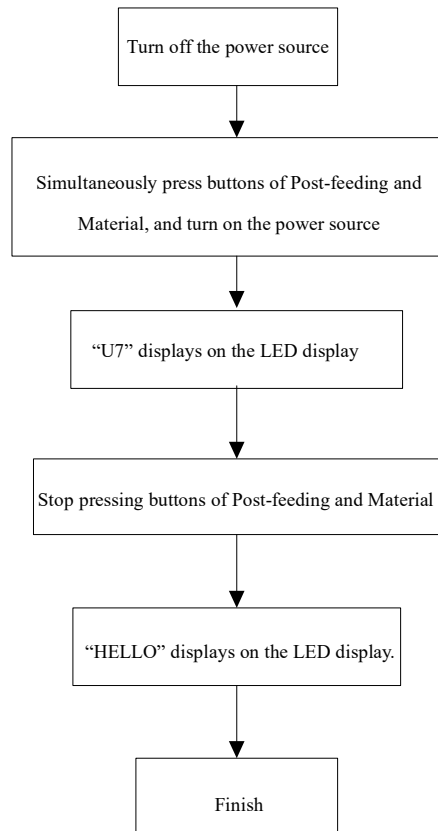

3.20.5 Restoring to Factory default settings

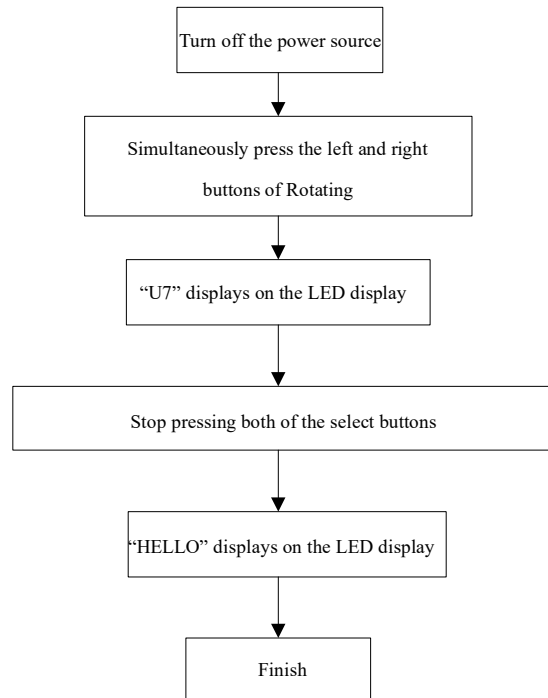

Notes

If there has been no firmware upgrading operation since the welding power source leaving the factory, the restore to factory default program method should be used when upgrading the firmware of the communication switching panel (box)

Chapter 4 Configuration of welding power source features

4.1 Configuration of welding program parameters

4.1.1 Selection of control mode for the welding power source (P02)

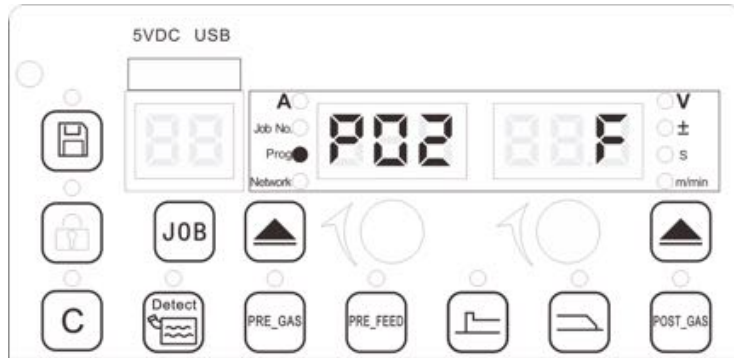

Figure 4-1 P02 View

Steps:

1. Press the left select button to select “Program”, turn the left knob to select P02, with F being default;
2. Turn the right knob to select the relevant control mode. Description for the welding power source control modes is shown in Table 4-1.

Table 4-1 Description for control modes

DISPLAY	F	N	DF	DN
Control mode	Wire-feeder control	Power source control	Robotic synergy control	Robotic JOB calling control

Notes

1. F: The wire-feeder control mode means that the wire-feeder can control the welding torch switch, inching, gas test, main wire feeding speed, and the arc length factor under JOB NO.10 while other parameters are set by the welding power source.
2. N: The power source control mode means the wire-feeder can only control the welding torch switch, inching feeding and gas test while other parameters are set by the panel of the welding power source.
3. DF: robotic synergy control means that the robotic can control the welding torch switch, inching feeding, reverse wire drawing, gas check, failure clearing, main wire feeding speed and arc length factor for main wire feeding speed under JOB NO.10, while other parameters are set by the panel of the welding power source.
4. DN: The job calling control mode means that a robot will call the relevant channel to control the welding process, and the welding torch switch, inching, reverse wire drawing, gas check, failure clearing and JOB numbers, while other parameters are set by the panel of welding power source.

4.1.2 Activating the Water-cooling system for the welding power source (P03)

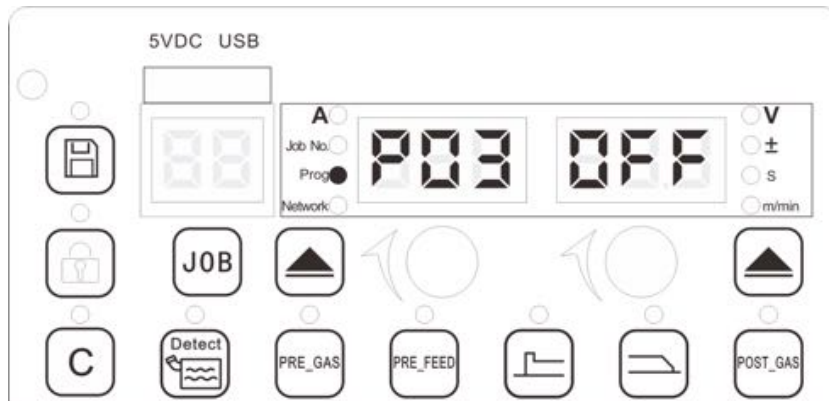

Figure 4-2 P03 View

Steps:

1. Press the select key to choose “program”, turn the left knob to P03;
2. Turn the right knob to select ON for activation, with OFF being default;
3. Pressing the water flow inspection button to check the water flow, the water cooler can be normally used after the water flow inspection finish.

Notes

1. Ensure the completeness and smoothness of the water path before activating the water-cooling system
2. Please use the water-cooling welding torch for the water cooler
3. Do not activate the water-cooling system if there is not a water-cooling device equipped,; otherwise the welding power source cannot be normally used;
4. The welding power source from Megmeet will have a 380V AC power supply to drive the water tank equipped by the series welding power source from Megmeet;
5. Turn on the program parameter P03 (water tank enabling switch) at ON status (with OFF being a default status), and save the setting;
6. Water should be filled into the water tank first, and connect the water path properly to avoid the water-tank motor idle running before using. After the water tank is filled with water, click the “Water flow inspection” key on the panel of welding power source, and the water flow inspection will automatically stop in 50 seconds. There will be the warning of Err 25 when there is no water flow in the water path; Also, there will be Err25 if there is no water flowing back inspected in the water tank for more than 10 seconds, during welding.
7. There is no water flow inspection device equipped for parts of water tank, in this case the program parameter P09 (water flow inspection switch) should be turn at OFF status (with ON being a default) and save the setting; otherwise, the failure code of Err 25 will be presented in 10 seconds after the welding is started.

4.1.3 Activating robotic communication module (P05)

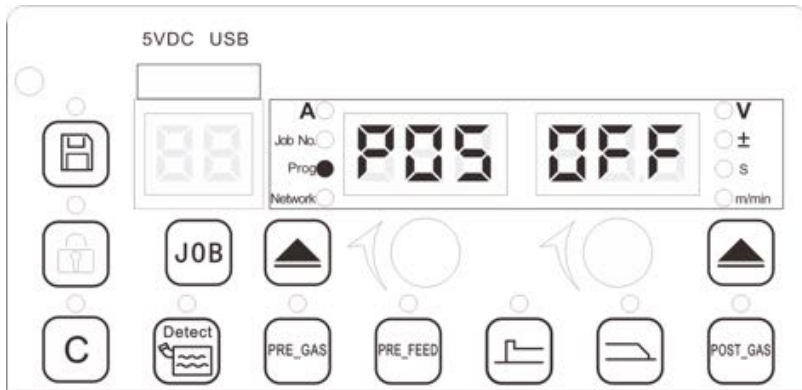

Figure 4-3 P05 view

Steps:

1. Press the select button on the left select button to select “Program”, turn the left knob to select P05;
2. Turn the right knob to select ON for activation, with OFF being default.

Notes

The welding power source must be connected with a communication box after the communication module being activated; otherwise there will be a warning presented.

4.1.4 Selection of wire-feeder (P06)

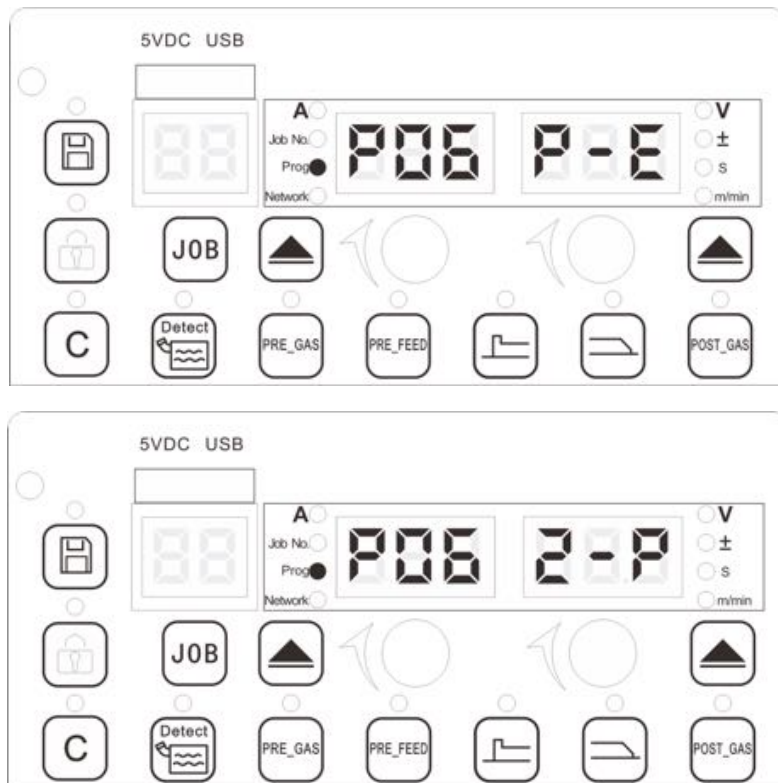

Figure 4-4 P06 view

Steps:

1. Press the select button on the left select button to “Program”, turn the left knob to select P06;
2. Turn the Right knob to select P-E/P-P/Z-P, for Plus, the default is P-E, for Pro, the default is Z-P.
(Note: P-E is suitable for WF12-50PR, WF12-50P, WF2-50PLR, WF2-50PL wire-feeders; P-P is suitable for WF2-50PP wire-feeder; Z-P is suitable for WF2-50ZP-MD wire-feeder.)

Note

The welding process will be abnormal if there is a wrong wire-feeder model selected..

4.1.5 JOB display (P07)

Figure 4-5 P07 view

Steps:

1. Press the Left select button to select “Program”, turn the Left knob to select P07;
2. Turn the Right knob to select ON for activation, with OFF being default.

Notes

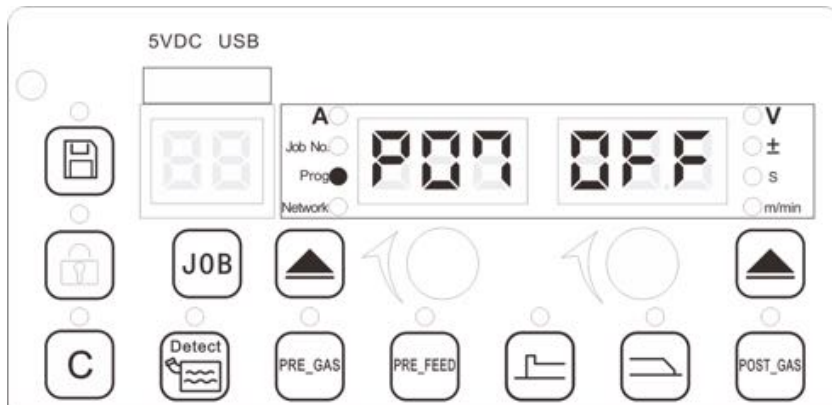
1. ON: All the parameters will be displayed and they are adjustable when activate the commissioning mode
2. OFF: .Only parts of parameters are adjustable when activate the user mode.

4.1.6 Crater fill ON/OFF (P08)

Figure 4-6 P08 view

Steps:

1. Press the select button on the left to select “Program”, turn the Left knob to select P08;
2. Turn the Right knob to select ON for activation, with OFF being default.

4.1.7 Activating water flow inspection (P09)

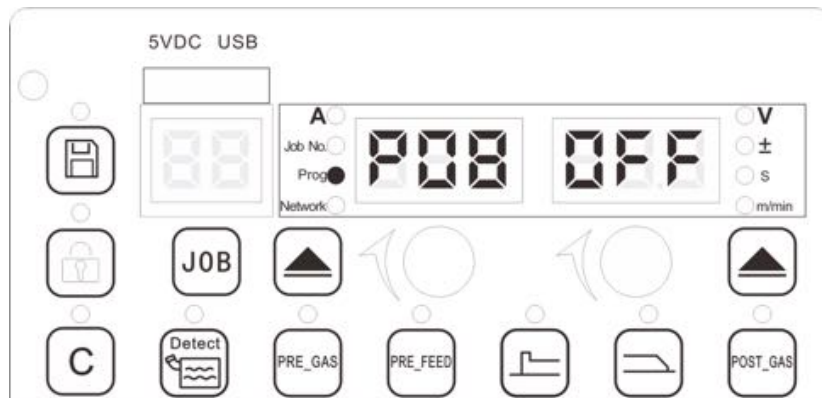
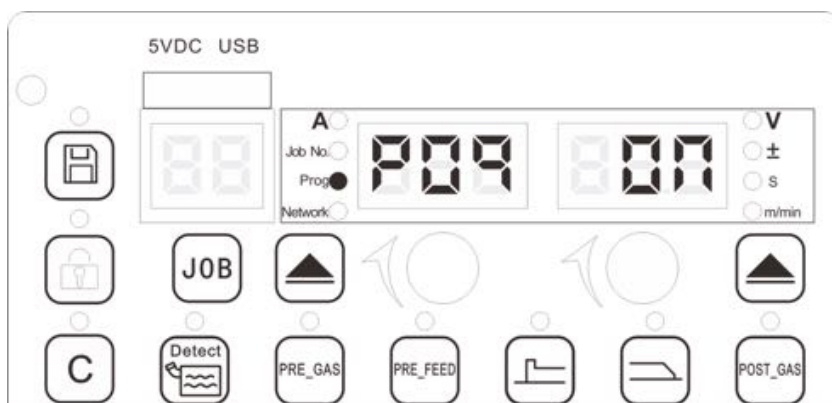

Figure 4-7 P09 view

Steps:

1. Press the select button on the left to select “Program”, turn the Left knob to select P09;
2. Turn the right knob to select ON for activation, with ON being default.

Notes

1. ON: The water flow inspection function activates.
2. OFF: The water flow inspection function is not activated.

4.1.8 Activating LED display on wire-feeder (P10)

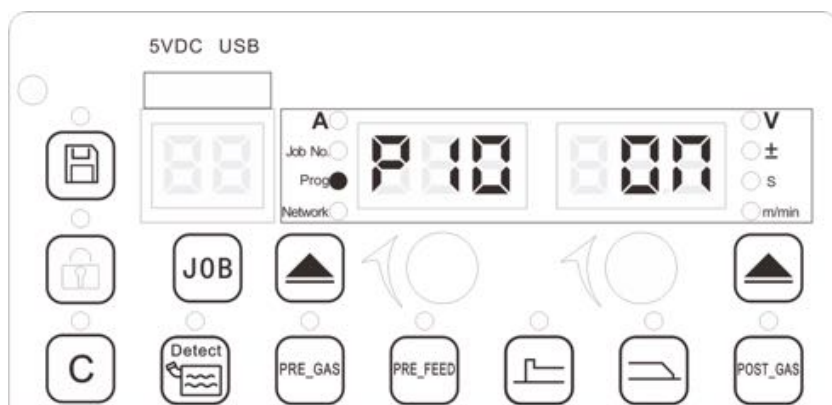

Figure 4-8 P10 view

Steps:

1. Press the select button to select “Program”, turn the left knob to select P10;
2. Turn the Right knob to select ON for activation, with ON being default.

Notes

1. ON: The wire-feeder display panel function is activated; OFF: The wire-feeder display panel function is not activated.
2. The P10 enabling switch should be set at OFF status if the wire-feeder does not have a display function; otherwise the relevant parameters cannot be adjusted.

4.1.9 Activating low-spatter module (P11)

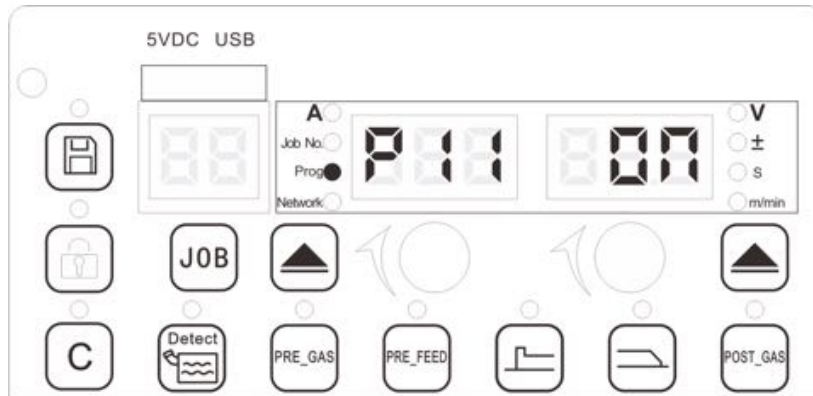

Figure 4-9 P11 view

Steps:

1. Press the select button on the left to select “Program”, turn the left knob to select P11;
2. Turn the right knob to select ON for activation, with ON being default.

Notes

1. Low spatter module (with ON as a default status) is needed to be activated for short-circuit transfer low spatter welding technique.
2. If the welding torch length is relatively long, and the voltage inspection wire does not extend to the end of the welding torch when using the pushing-pulling wire welding torch, the low spatter function should be turned off to avoid the unstable welding status owing to decreased inspection accuracy.
3. For Artsen Pro welding power source, the default status of this function is OFF.

4.1.10 Activating push-pull system (P12)

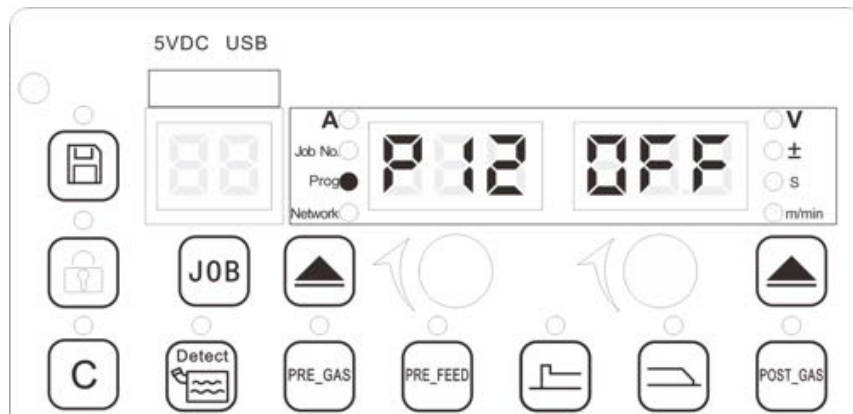

Figure 4-10 P12 view

Steps:

1. Press the select button on the left to select “Program”, turn the Left knob to select P12;
2. Turn the Right knob to select ON for activation, with OFF being default.

Notes

1. Currently only support TBi-PP2R pushing-pulling wire system (PP-TX-17V wire-pulling motor);
2. The panel of welding power source will display the current of the wire-pulling motor when inching feeding status;

Steps for adjustment:

- a) Adjust the pressing force of the main motor to a proper value;
 - b) Adjust the pressing force of the wire-pulling motor and adjust the current of the wire-pulling motor to a proper value after the wire feeds successfully(at a default parameter, the value is generally within the scope of 0.5~0.7A);
 - c) Turn to P13 and observe the current of the wire-pulling motor to see whether the parameter is proper or not.
3. When the pushing-pulling wire welding torch length is relatively long, and the voltage inspection wire does not extend to the end of the welding torch, we recommend that the low spatter function should be turned off (P11 = OFF), avoiding the unstable welding status owing to decreased inspection accuracy.
 4. We recommend that the parameter C29 should be adjusted simultaneously for using pulse technique when the pushing-pulling wire welding torch length is relatively long and the voltage inspection wire does not extend to the end of the welding torch to improve arc control accuracy.

4.1.11 Force adjustment of the pulling motor 1 (P13)

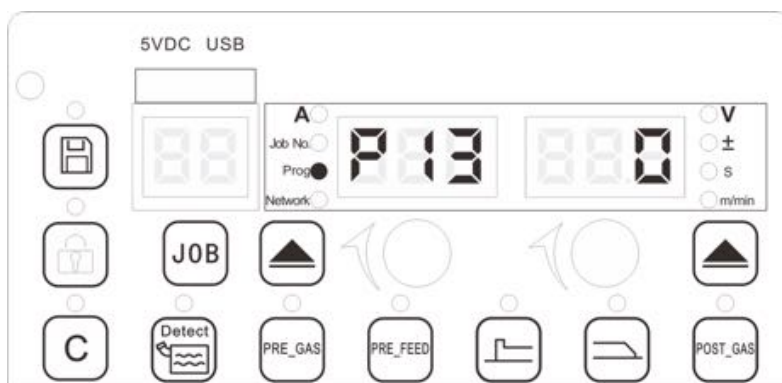

Figure 4-11 P13 view

Steps:

1. Press the select button on the left to select “Program”, turn the left knob to select P13;
2. Turn the right knob to select the adjustment factor value, with 0 as a default value.

Note

Scope: -7~+7, the bigger the factor is, the bigger the pulling force.

4.1.12 Force adjustment 2 of the pulling motor (P14)

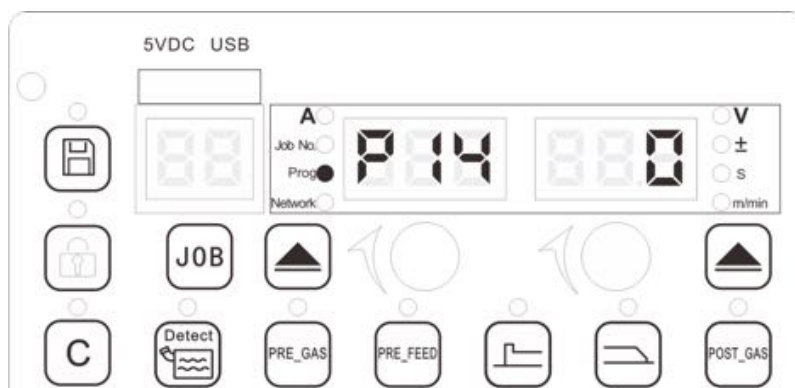

Figure 4-12 P14 view

Steps:

1. Press the select button on the left to select “Program”, turn the Left knob to select P14;
2. Turn the Right knob to select the adjustment factor value, with 0 as a default value.

Note

Scope: 0~6, the bigger the factor is, the smaller the pulling force.

4.1.13 Switch between displaying pre-set and realistic parameters (P15)

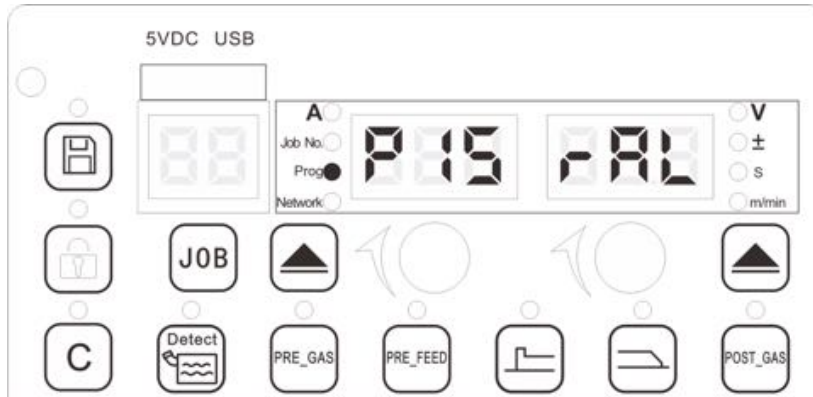

Figure 4-13 P15 view

Steps:

1. Press the I select button to select “Program”, turn the Left knob to select P15;
2. Turn the Right knob to activate the relevant function (SET shows the setting value, and RAL shows real value, defaults RAL.)

4.1.14 Switch between displaying wire-feeding speed and welding

Current (P16)

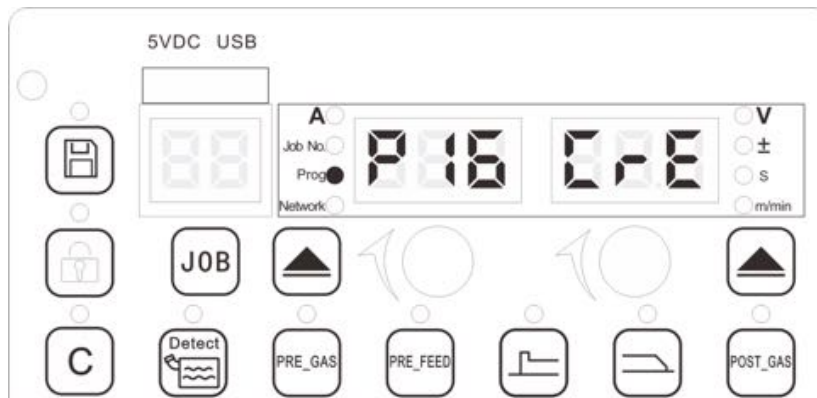

Figure 4-14 P16 view

Steps:

1. Press the select button on the left to select “Program”, turn the Left knob to select P16;
2. Turn the right knob to activate the relevant function, CRE means current and SPD means the wire feeding speed. It is set to CRE by default.

4.1.15 Switching between welding mode (P17)

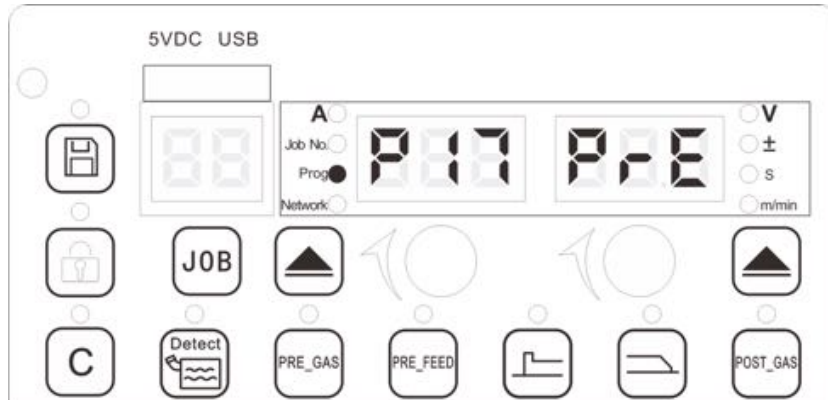

Figure 4-15 P17 view

Steps:

1. Press the select button on the left to select “Program”, turn the Left knob to select P17;
2. Turn the Right knob to select the relevant parameter, ROG means the anti-noise mode, and PRE means precise mode. It is PRE by default.

4.1.16 Activating the No-load protection (P19)

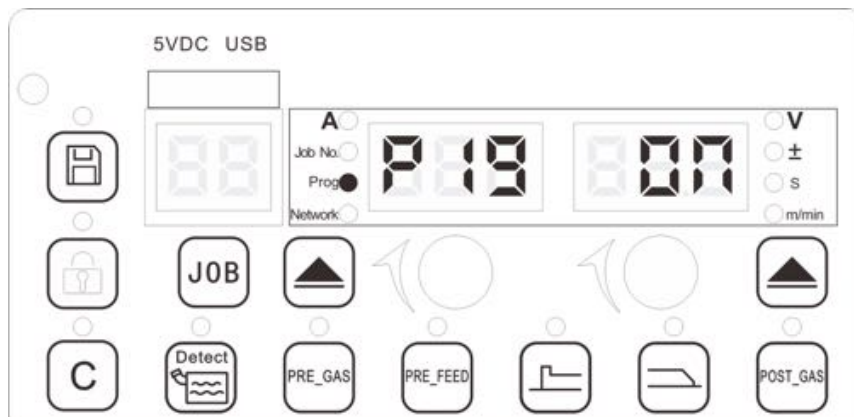

Figure 4-16 P19 view

Steps:

1. Press the select button on the left to select “Program”, turn the Left knob to select P19;
2. Turn the Right knob to select ON for activation, ON by default.

4.1.17 Switching between displaying correction ratio and absolute value of wire-feeding (P20)

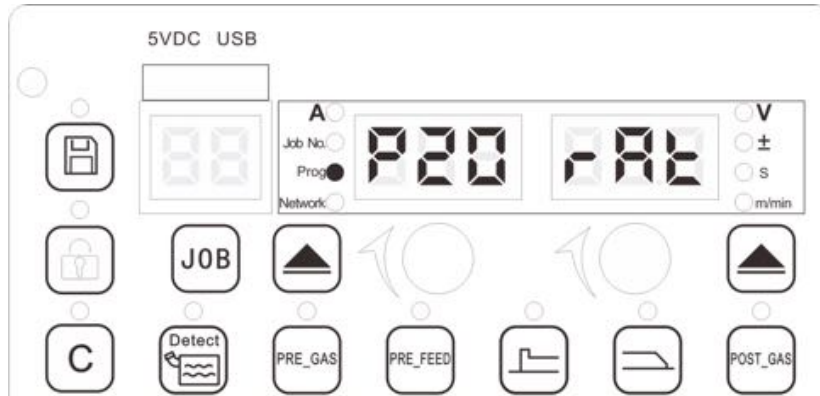

Figure 4-17 P20 view

Steps:

1. Press the select button on the left to select “Program”, turn the Left knob to select P20;
2. Turn the Right knob to select the relevant parameter. Rat means ratio and ABS means absolute value. RAT is default.

4.1.18 Activation of weld penetration depth control (P21)

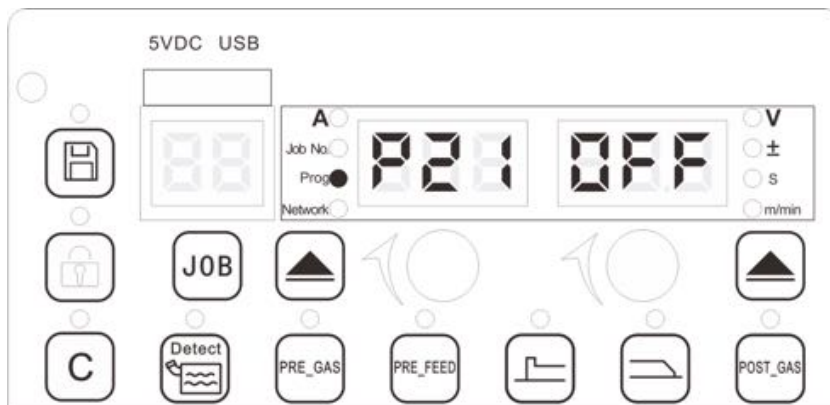

Figure 4-18 P21 view

Steps:

1. Press the select button on the left to select “Program”, turn the Left knob to select P21;
2. Turn the Right knob to select ON for activation, with OFF being default.

4.1.19 Sensitivity adjustment of low-spatter module(P22)

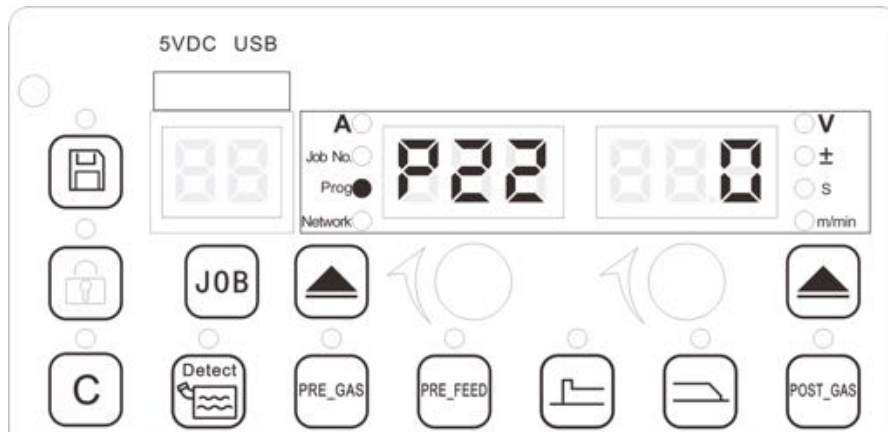

Figure 4-19 P22 view

Steps:

1. Press the select button on the left to select “Program”, turn the Left knob to select P22;
2. Turn the Right knob to adjust the factor, its scope is of -10~10 mV, with 0 mV as default.

4.1.20 Activating parameter correction of welding circuit parameter

(P23)

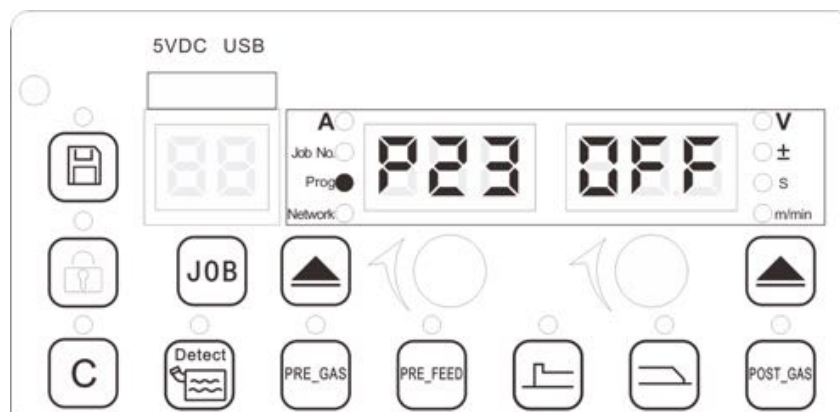

Figure 4-20 P23 view

Steps:

1. Press the select button on the left to select “Program”, turn the Left knob to select P23;
2. Turn the Right knob to select ON for activation, with OFF being default.

4.1.21 Resistance compensation of welding circuit (P24)

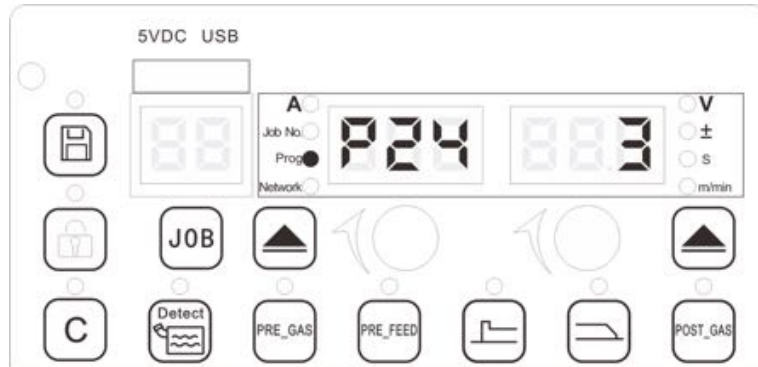

Figure 4-21 P24 view

Steps:

1. Press the select button on the left to select “Program”, turn the Left knob to select P24;
2. Turn the Right knob to adjust the factor, its scope is of 0~30 m Ω , with 3 m Ω as default.

4.1.22 Inductance compensation for welding circuit (P25)



Figure 4-22 P25 view

Steps:

1. Press the select button on the left to select “Program”, turn the Left knob to select P25;
2. Turn the Right knob to adjust the factor, its scope is of 0~120 uH, with 6 uH as default.

4.1.23 Activating twin-wire welding mode (P26)

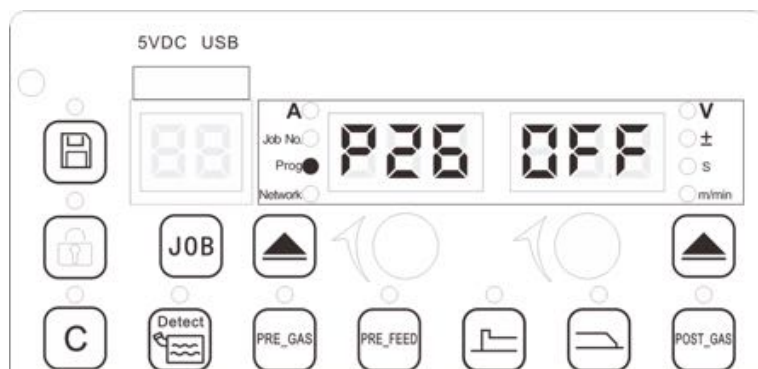

Figure 4-23 P26 view

Steps:

1. Press the select button on the left to select “Program”, turn the Left knob to select P26;
2. Turn the Right knob to select ON for activation, with OFF being default.

Note: Please contact the factory to activate this function if need be.

4.1.24 Adjustment of starting arc stabilization time (P27)

Figure 4-24 P27 view

Steps:

1. Press the select button on the left to select “Program”, turn the Left knob to select P27;
2. Turn the Right knob to adjust the factor, its scope is of $-7\sim 7$, with 0 as default.

4.1.25 Adjustment of starting arc stabilization voltage (P28)

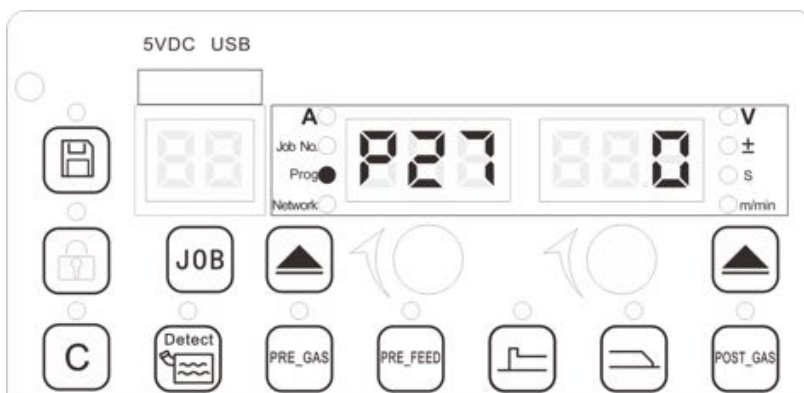
Figure 4-25 P28 view

Steps:

1. Press the select button on the left to select “Program”, turn the Left knob to select P28;
2. Turn the Right knob to adjust the factor, its scope is of $-7\sim 7$, with 0 as default.

4.1.26 Switch of duty cycle mode (P29)

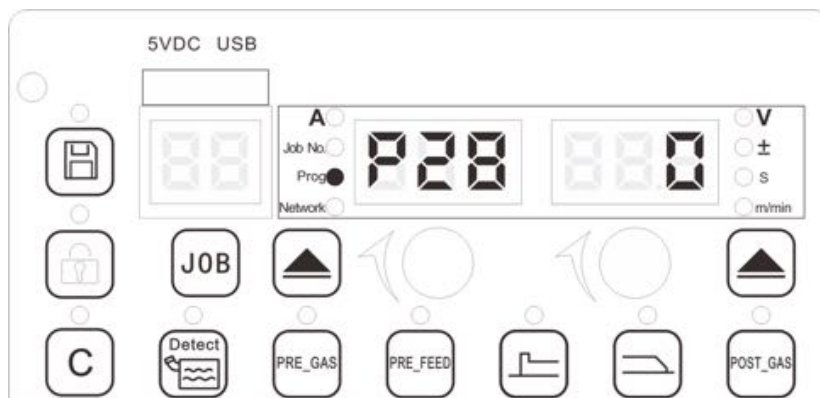
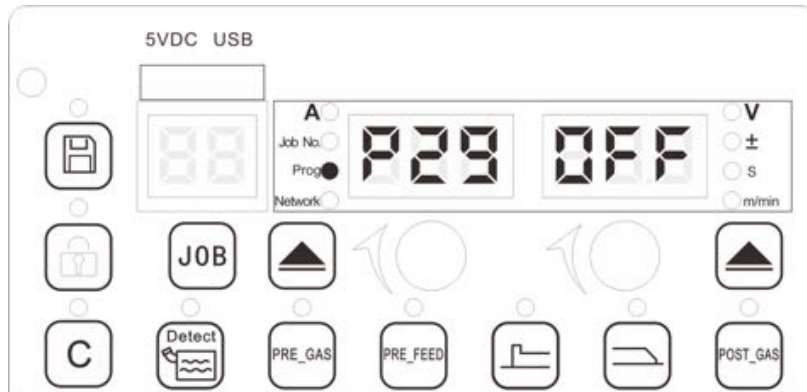

Figure 4-26 P29 view

Steps:

1. Press the select button on the left to select “Program”, turn the Left knob to select P29;
2. Turn the Right knob to ON for activation, with ON being the duty cycle mode, OFF being the common mode, and OFF as default.

4.1.27 Checking software version of welding power source display broad (P30)

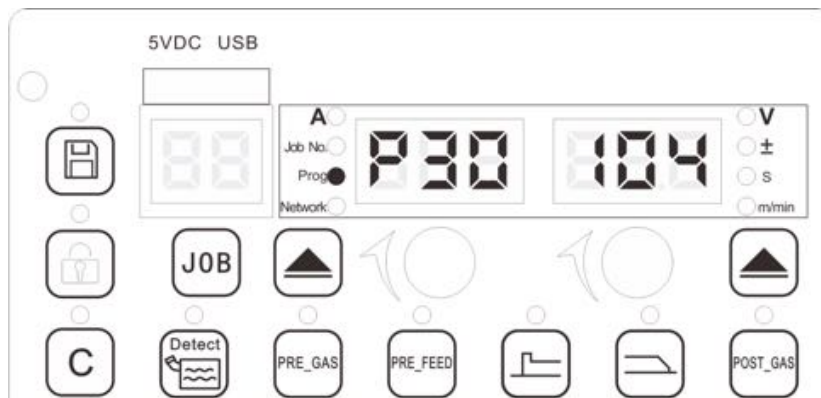

Figure 4-27 P30 view

Steps:

- Press the select button on the left to select “Program”, turn the Left knob to select P30; the right LED display will show the software version number.

4.1.28 Checking software version of motor drive board (P31)

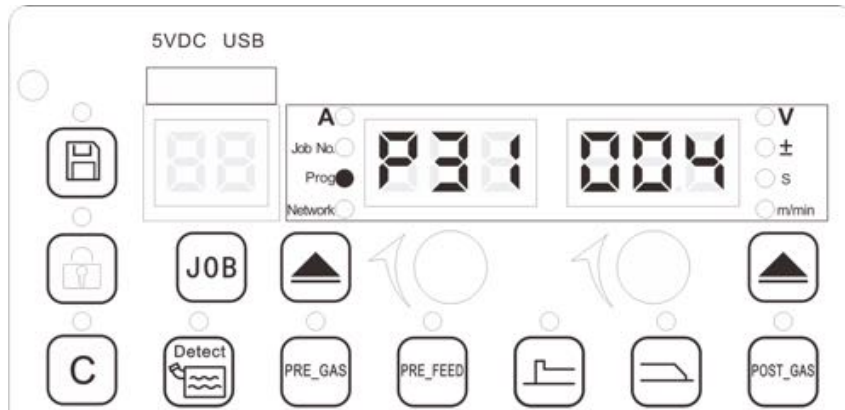

Figure 4-28 P31 view

Steps:

Press the select button on the left to select “Program”, turn the left knob to select P31; the right LED display will show the software version number for motor driving panel.

4.1.29 Checking software version of welding power source control board (P32)

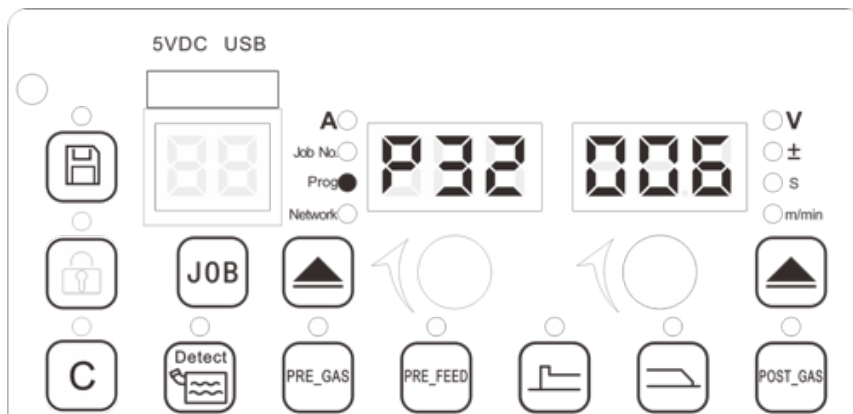

Figure 4-29 P32 view

Steps:

Press the select button on the left to select “Program”, turn the Left knob to select P32; the right LED display will show the software version number for the control panel of the welding power source.

4.1.30 Checking software version of wire-feeder display broad (P33)

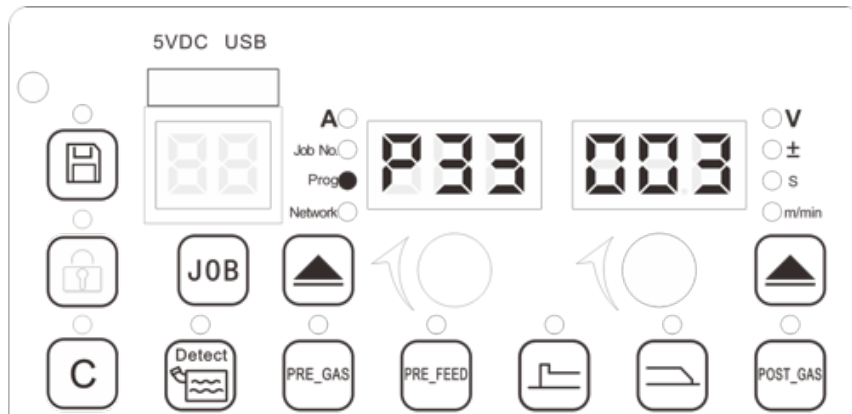

Figure 4-30 P33 view

Steps:

Press the select button on the left to select “Program”, turn the Left knob to select P33 and the software version number will show on the right LED display.

4.1.31 Checking software version of communication connection broad (P34)

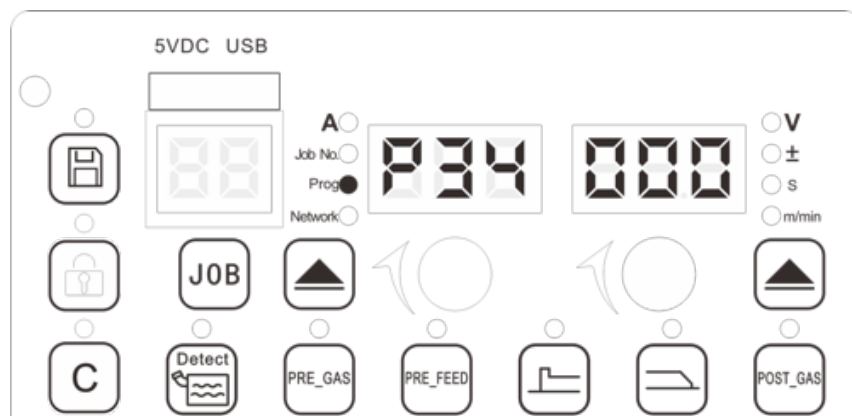

Figure 4-31 P34 view

Steps:

Press the select button on the left to select “Program”, turn the Left knob to select P34 and the software version number for the communication switch panel will show on the right LED display..

4.1.32 Checking software version of Ethernet communication connection Broad/Box (P35)

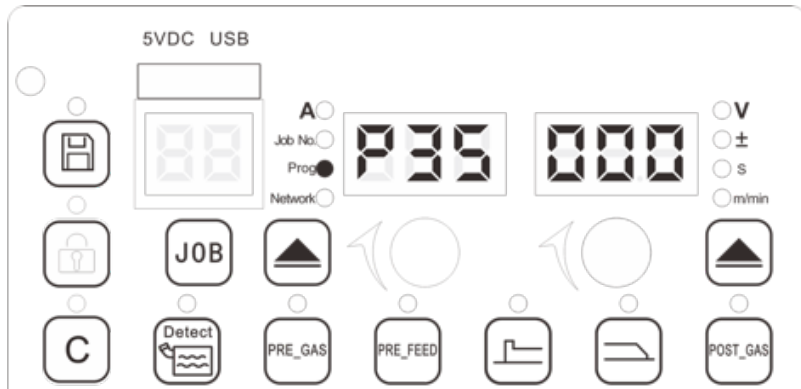

Figure 4-32 P35 view

Steps:

Press the select button on the left to select “Program”, turn the Left knob to select P35;The software version number for the Ethernet communication switch panel (box) will show the right LED display..

4.1.33 Checking welding process software (P40)

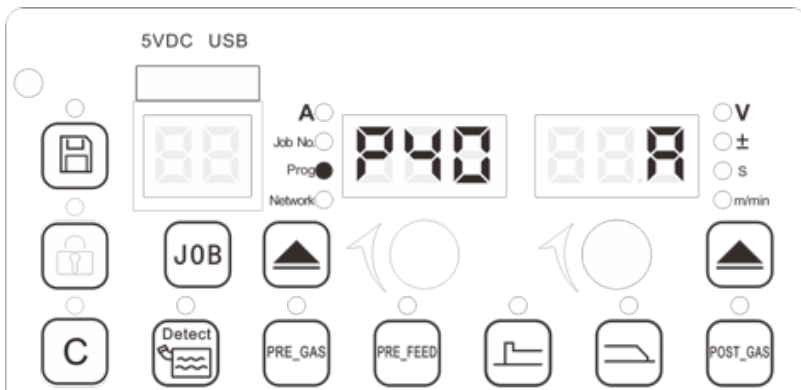

Figure 4-33 P40 view

Steps:

Press the select button on the left to select “Program” and turn the Left knob to select P40; The relevant welding technique software package. will show the right LED display.

For the details of welding technique software packages, see Table 4-2.

Table 4-2 Description of the welding technique software packages

Model	Welding materials	Technique type	Synergy	High speed intermittent welding	DP synergy
D	Solid carbon steel, solid stainless steel	Short-circuit transfer low spatter	No	No	No
DD	Solid carbon steel, solid stainless steel	Short-circuit transfer low spatter	Yes	Yes	No
PP	Solid carbon steel, solid stainless steel	Short-circuit transfer low spatter, short arc pulse	Yes	Yes	No
DP	Solid carbon steel, solid stainless steel	Short-circuit transfer low spatter, short arc pulse	Yes	Yes	Yes
A	Carbon steel, stainless steel,	Short-circuit transfer low	Yes	Yes	Yes

aluminum alloy	spatter, short arc pulse			
----------------	--------------------------	--	--	--

4.1.34 Checking power grade of welding power source (P41)

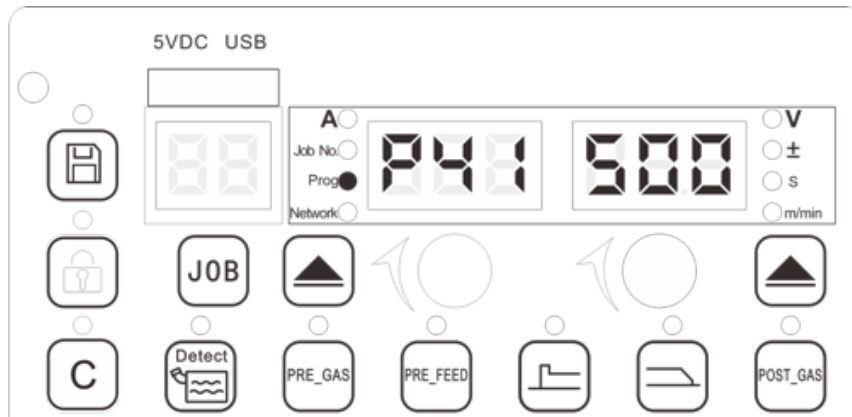

Figure 4-34 P41 view

Steps:

1. Press the select button on the left to select “Program”, turn the Left knob to select P41;
2. The right LED display will show the relevant power for the welding power source.

For the details of power for the welding power source, see Table 4-3.

Table 4-3 Description of the power grade for the welding power source

	Power grade
350	60%@350A/31.5V
400	100%@400A/34V
500	60%@500A/39V
630	100%@500A/39V

4.1.35 Checking product series of welding power source (P42)

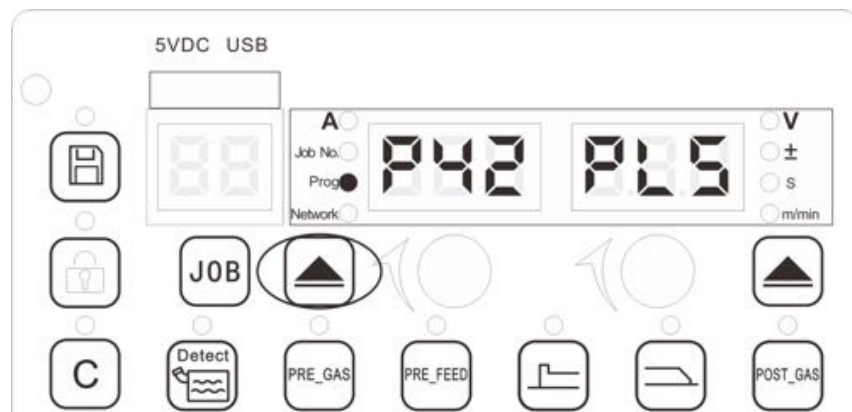

Figure 4-35 P42 view

Steps:

1. Press the select button on the left to select “Program”, turn the Left knob to select P42;
2. The LED display will show the relevant welding power source product series on the right.

For the details of product series for the welding power source, see Table 4-4.

Table 4-4 Description of the product series for the welding power source

	Welding power source series
PLS	Artsen Plus series of welding power source
PRO	Artsen Pro series of welding power source

4.1.36 Checking input voltage type (P43)

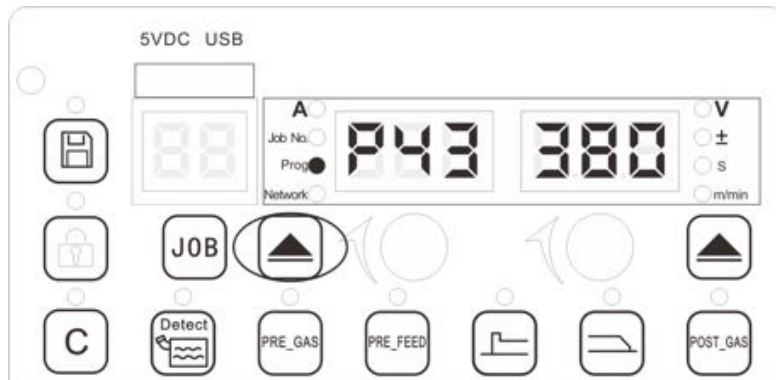
**Figure 4-36 P43 view**

Steps:

1. Press the select button on the left to select “Program”, turn the Left knob to select P43;
2. The right LED display will show the relevant input voltage specification for the welding power source.

For the details of input voltage specification for the welding power source, see Table 4-5.

Table 4-5 Description of the input voltage specification for the welding power source

	Input voltage specification
380	Rated input voltage 380VAC (three-phase system without a neutral line)
220	Rated input voltage 220VAC (three-phase system without a neutral line)

4.1.37 Checking hardware code of welding power source (P50)

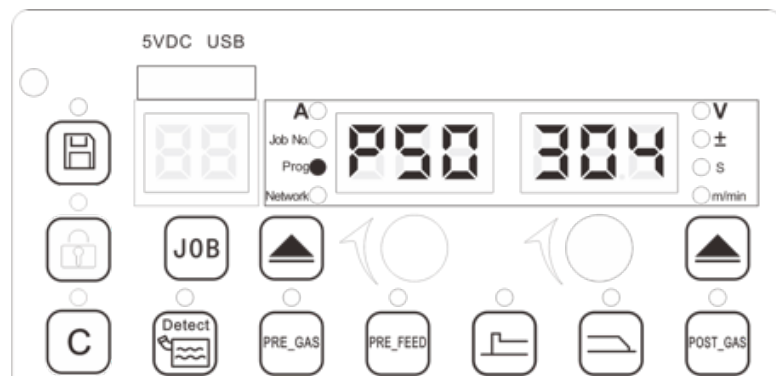
**Figure 4-37 P50 view**

Steps:

1. Press the select button on the left to select “Program”, turn the Left knob to select P50;
2. The right LED display will show the hardware code parameter for the welding power source.

4.1.38 Checking bar code of welding power source (P51)

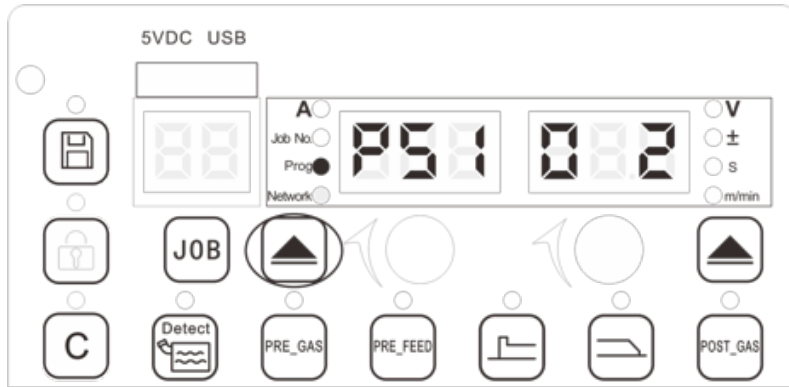

Figure 4-38 P51 view

Steps:

1. Press the select button on the left to select “Program”, turn the Left knob to select P51;
2. The right LED display will show the relevant bar code for the welding power source;
3. Turn the Left knob, the 0 -9 position bar code information will be presented successively;
4. The codes shows one by one according to the serial numbers, thus forming a complete bar code for the welding power source.

For an example of a bar code for the welding power source, see table 4-6.

Table 4-6 An example of a bar code for the welding power source

Parameter	Digital tube 1 (Serial number)	Digital tube 2 (Bar code data)	Digital tube 3 (Bar code data)
P51	0	/	Z
	1	/	Z
	2	0	1
	3	2	3
	4	4	5
	5	6	7
	6	8	9
	7	0	1
	8	2	3
	9	4	
Bar code	ZZ012345678901234		

4.1.39 Adjustment of wire-feeding speed (P60)

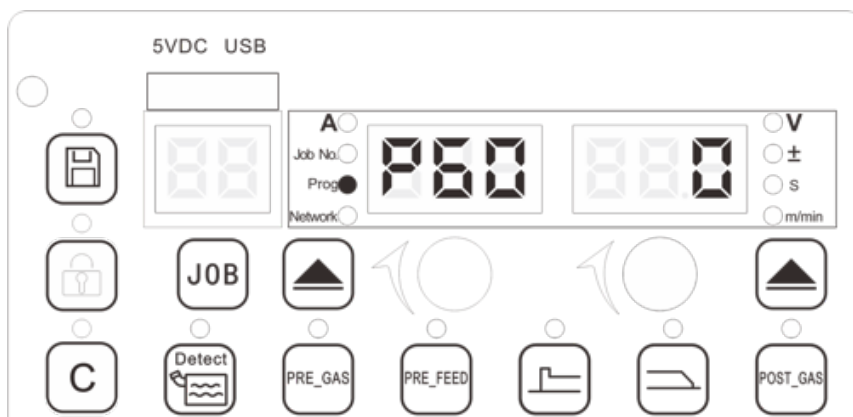
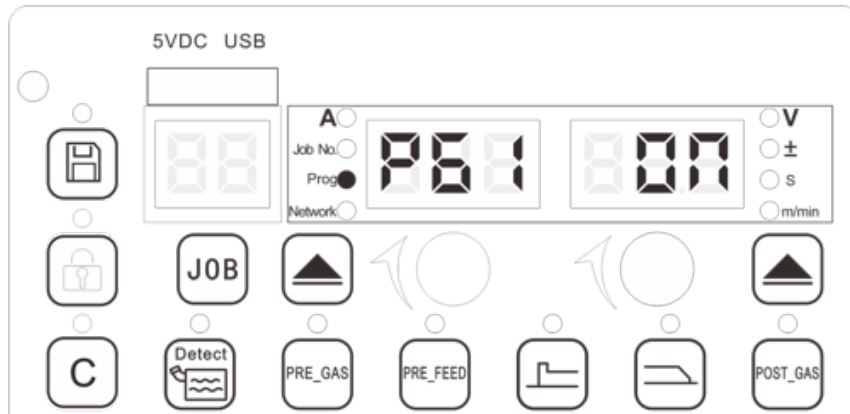
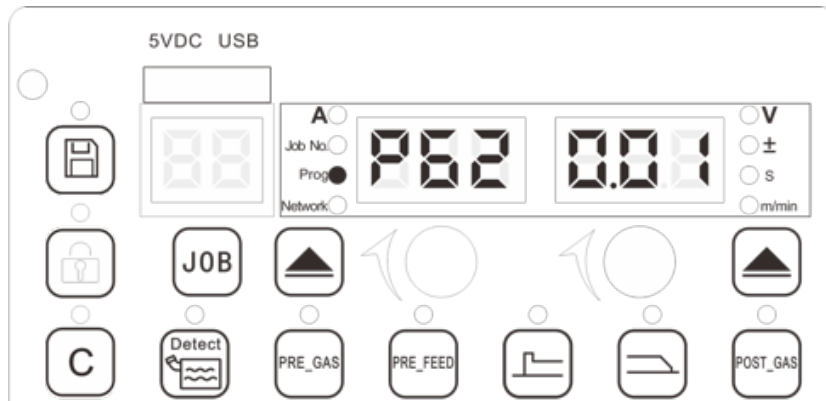

Figure 4-39 P60 view**Steps:**

1. Press the select button on the left to select “Program”, turn the Left knob to select P60;
2. Turn the Right knob to adjust the wire feeding speed when the welding condition changes, with its scope is of -30~30, 0 as default.

4.1.40 On/Off switch of current wave correction for starting arc (P61)**Figure 4-40 P61 view****Steps:**

1. Press the select button on the left to select “Program”, turn the Left knob to select P61;
2. Turn the Right knob to select the relevant function, with ON for activation of the enabling switch, OFF for deactivation of the enabling switch, and ON being default.

4.1.41 Adjustment of inspection time of crater (P62)**Figure 4-41 P62 view****Steps:**

1. Press the select button on the left to select “Program”, turn the Left knob to select P62;
2. Turn the Right knob to adjust the arc break inspection time, with its scope is of 0.01s~0.5s, 0.01s as default.

4.1.42 Activating constant opening of cooling fan (P63)

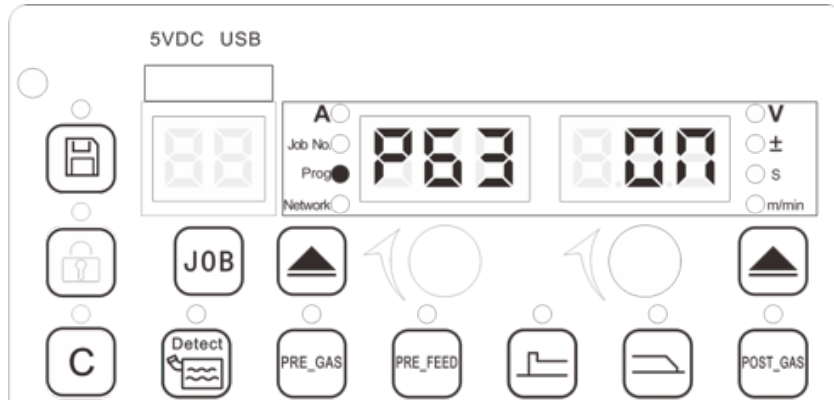

Figure 4-42 P63 view

Steps:

1. Press the select button on the left to select “Program”, turn the Left knob to select P63;
2. Turn the right knob to select the relevant function, with ON for activation of the enabling switch, OFF for deactivation of the enabling switch, and OFF being default.

4.2 Configuration of welding network parameters

4.2.1 Configuration of robot protocol (N00)

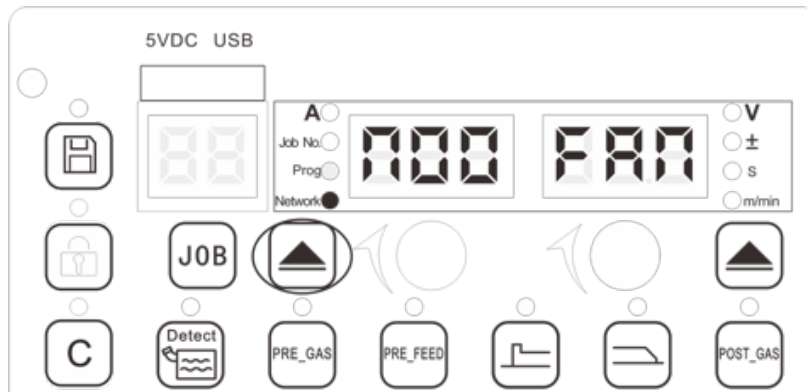

Figure 4-43 N00 view

Steps:

1. Press the select button on the left to select “Network”, and turn the Left knob to select N00;
2. Turn the Right knob to select the relevant protocol.

The details of the protocols for N00 is shown in Table 4-7

Table 4-7 List of relevant protocols

Protocol number	Partners	Application layer protocol
FAN	Fanuc	DeviceNet
ABB	ABB	DeviceNet
CCA	Kuka	DeviceNet
CLP	Chengdu Kano	DeviceNet
ESD	Estun	CanOpen
FOD	Fanuc ODM	DeviceNet
GSD	Guangzhou Numerical Control	DeviceNet

FNE	Fanuc	Ethernet/IP
FOE	Fanuc ODM	Ethernet/IP
STP	Step Electric	CanOpen
GOG	Googol Tech	Can
SIA	Siasun	DeviceNet
ANG	/	Analog port

4.2.2 Configuration of MAC ID of welding power source (N01)

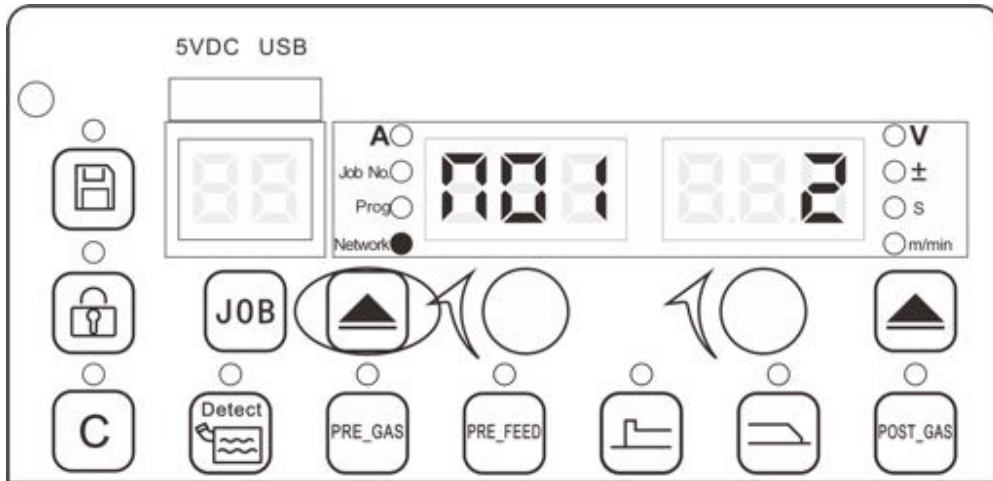

Figure 4-44 N01 view

Steps:

1. Press the select button on the left to select “Network”, and turn the Left knob to select N01;
2. Turn the Right knob to select the relevant ID, with its scope of 0~63 and 2 as default.

Note

The secondary station MAC ID is the MAC ID of the welding power source, with 2 as its default; If it is not repetitive with the robot MAC ID, such ID may be set at any value in the range of 0~63 in N01.

4.2.3 Configuration of Robot MAC ID (N02)

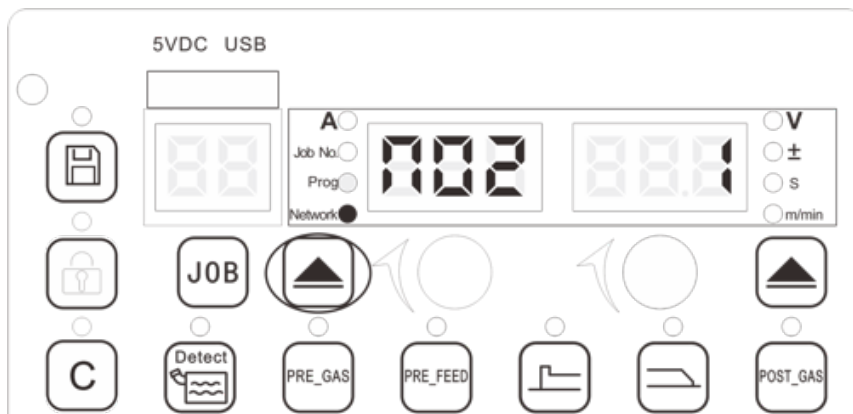

Figure 4-45 N02 view

Steps:

1. Press the select button on the left to select “Network”, and turn the left knob to select N02;
2. Turn the right knob to select the relevant ID, with its scope of 0~63 and 1 as default.

Note

Main station MAC ID is the MAC ID of the robot, and if it is not repetitive with the MAC ID of the welding power source, such ID may be set at any value within the scope of 0-63.

4.2.4 Baud rate of robot communication (N04)

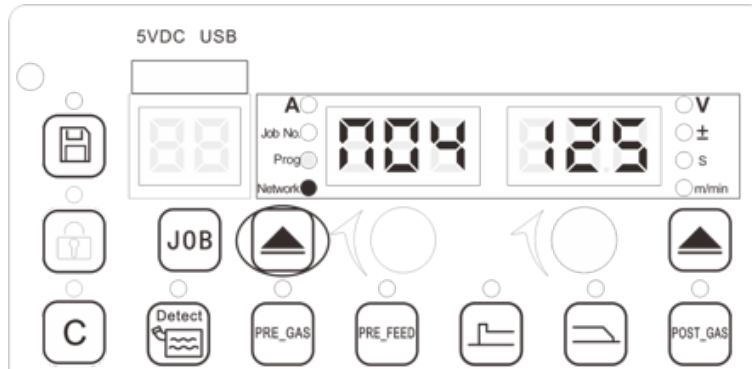

Figure 4-46 N04 view

Steps:

1. Press the select button on the left to select “Network”, and turn the left knob to select N04;
2. Turn the Right knob to select the relevant baud rate, with its value of 125kbps, 250kbps or 500kbps, and 125kbps as default.

4.2.5 Reverse switch between low electrical level (0 for digital communication) and high electrical level (1 for digital communication) feedback signal of arc ignition (N05)

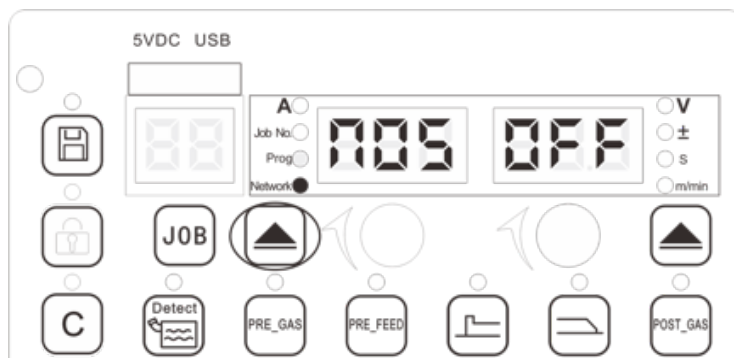

Figure 4-47 N05 view

Steps:

1. Press the select button on the left to select “Program”, turn the Left knob to select N05;
2. Turn the Right knob to select the relevant function, with ON for activation of the reverse switch and OFF as default.

4.2.6 Reverse switch between low electrical level (0 for digital communication) and high electrical level (1 for digital communication) ready signal of welding power source (N06)

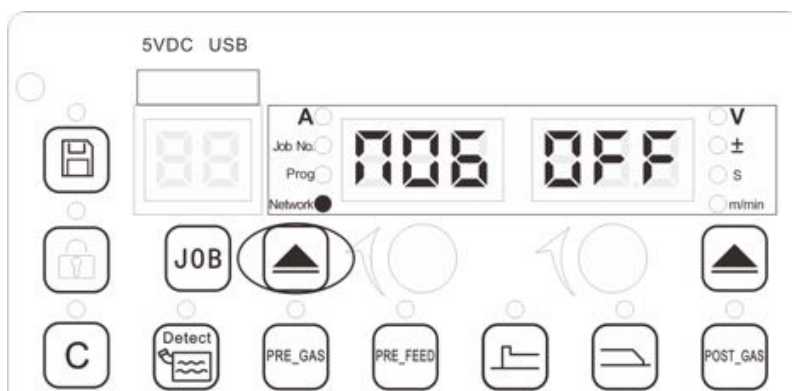

Figure 4-48 N06 view

Steps:

1. Press the select button on the left to select “Program”, turn the Left knob to select N06;
2. Turn the Right knob to select the relevant function, with ON for activation of the reverse switch and OFF as default.

4.2.7 Reverse switch between low electrical level (0 for digital communication) and high electrical level (1 for digital communication) for successful seam positioning (N07)

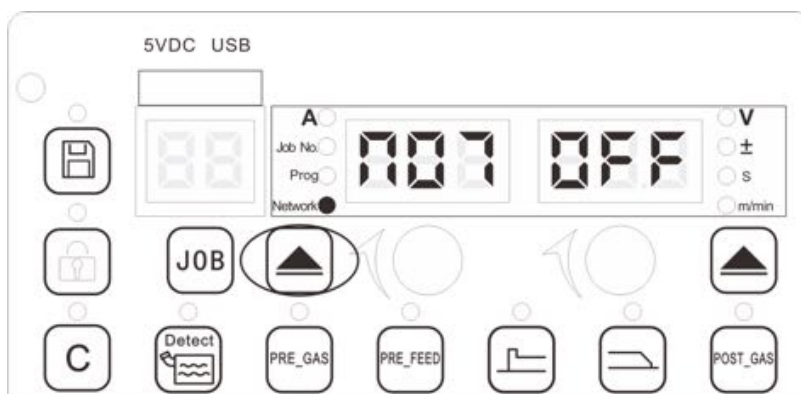

Figure 4-49 N07 view

Steps:

1. Press the select button on the left to select “Program”, turn the Left knob to select N07;
2. Turn the Right knob to select the relevant function, with ON for activation of the reverse switch and OFF as default.

4.2.8 Switch between pre-setting welding current of wire-feeding speed

(N08)

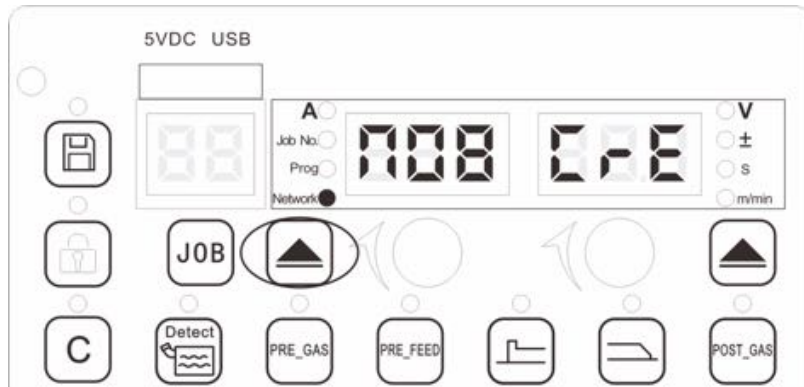

Figure 4-50 N08 view

Steps:

1. Press the select button on the left to select “Program”, turn the Left knob to select N08;
2. Turn the Right knob to select the relevant function, with CrE for the given current and SPD for the given wire feeding speed, and CrE as default.

4.2.9 Filter rate for welding parameters (N09)

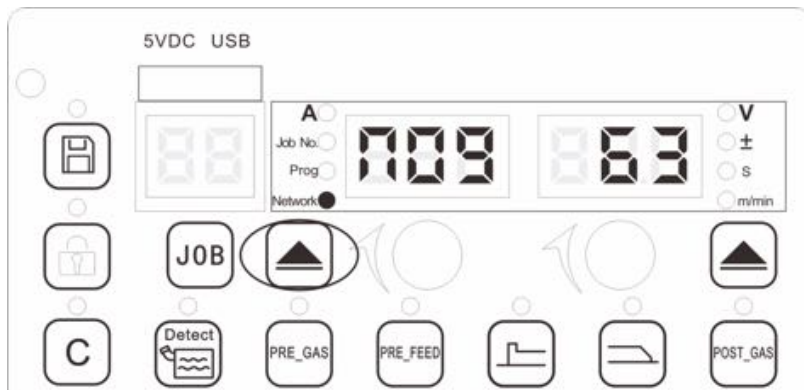

Figure 4-51 N09 view

Steps:

1. Press the select button on the left to select “Network”, and turn the Left knob to select N09;
2. Turn the Right knob to select the relevant filter factor, with its scope of 1~63 and 63 as default.

Notes

1. The bigger the filter factor, the smoother the output is and the longer the delay is;
2. The smaller the filter factor, the sharper the output is and the shorter the delay is.

4.2.10 Selection of welding mode (N10)

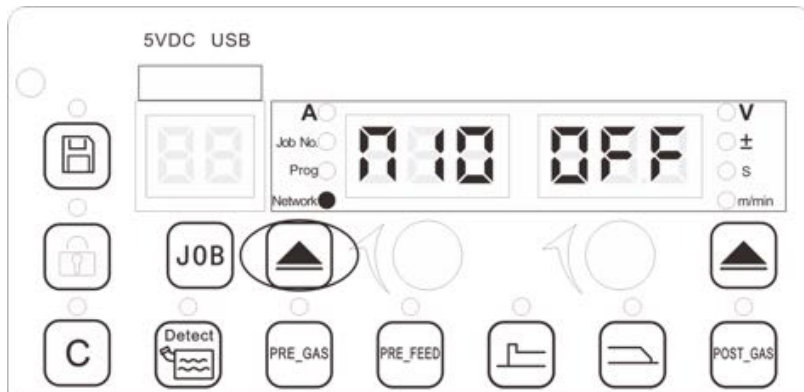

Figure 4-52 Welding mode view

Steps:

1. Press the select button on the left to select “Network”, and turn the Left knob to select N10;
2. Turn the Right knob to select the relevant mode, with ON for robot control welding mode, OFF for welding power source control welding mode, with OFF as default.

4.2.11 Selection of network parameters (N11)

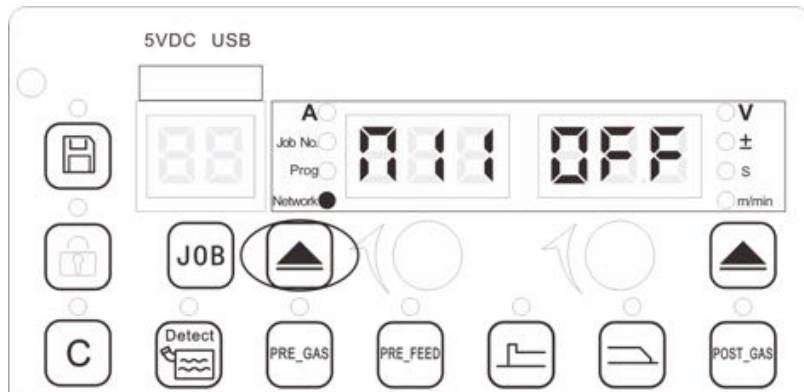

Figure 4-53 Network parameters view

Steps:

1. Press the select button on the left to select “Network”, and turn the Left knob to select N11;
2. Turn the right knob to select the relevant function, with ON for manual mode, OFF for synergy mode and OFF as default.

4.3 Configuration for channel parameters of the welding power source

4.3.1 Channel parameters

Steps:

Press the select button on the left to select “Channel”, and turn the left knob to select the relevant channel parameter.

The channel parameters are shown in Table 4-8.

Table 4-8 List of channel parameters

CHANNEL NUMBER	DESCRIPTION OF CHANNEL PARAMETERS
C00	Reserved
C01	JOB time duration
C02	Reserved
C03	Main wire feeding speed
C04	Main wire feeding speed correction rate
C05	Arc length factor for main wire feeding speed
C06	Slope factor for main wire feeding speed
C07~C10	Reserved
C11	Direct current arc characteristic factor 1
C12	Direct current arc characteristic factor 2
C13	Slope factor for short-circuit current
C14	Reserved
C15	Low spatter sensitivity factor 1
C16	Weld penetration adjustment factor
C17~C19	Reserved
C20	Pulse peak current amplitude factor
C21	Pulse peak current time factor
C22	Rising slope factor of pulse current
C24	Pulse basic current factor
C25	High pulse frequency factor
C27	Pulse arc characteristic factor 2
C28	Pulse arc adjustment factor
C29	Pulse arc length adjustment factor
C30	Synergy frequency
C31	Duty cycle for wire feeding speed of low-power section of double pulse
C32	Secondary wire feeding speed rate
C33	Arc length factor for wire feeding speed of low-power section of double pulse
C34	Slope factor of synergy wire feeding speed

4.3.2 Description of channel parameters

Channel parameter C01: JOB time duration

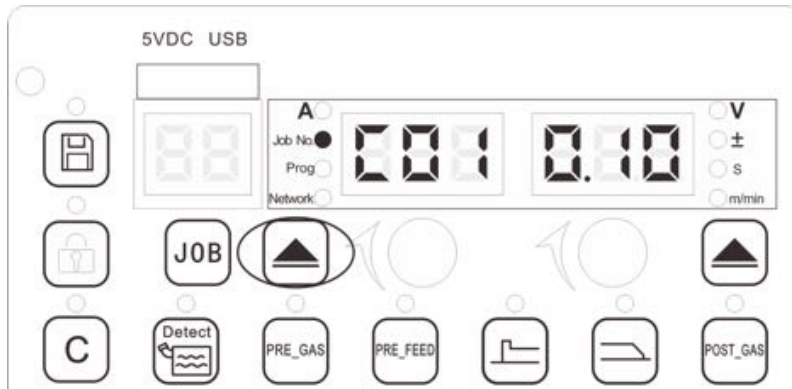

Figure 4-54 C01 view

Steps:

1. Press the select button on the left to select “Channel”, and turn the left knob to select C01;
 2. Press the select button on the right, turn the right knob to select the relevant time duration.
- Different JOB numbers correspond to different time setting. Specific parameters are shown in Table 4-9.

Table 4-9 List of time duration for JOB numbers

CHANNEL PARAMETER	JOB NUMBER	SCOPE (S)	PRECISION	EXPLANATION
C01	Pre-gas	0.1~10 (s)	0.1	Time duration for Pre-gas
	Pre-feeding	0.1~10 (cm)	0.1	Wire advancing distance at no-load protection
	Starting arc parameters	0~10 (s)	0.1	Time duration for hot starting
	Crater fill parameters	0~10 (s)	0.1	Time duration for hot filling arc crater
	Time duration for Post-gas	0~10 (s)	0.1	Time duration for Post-gas

Channel parameters of C03, C04, C05 and C06: main channel parameters

Steps:

Press the select button on the left to select “Channel”, and turn the Left knob to select the relevant channel parameter.

The main channel parameters are shown in Figure 4-55, and for the description of these parameters, see Table 4-10.

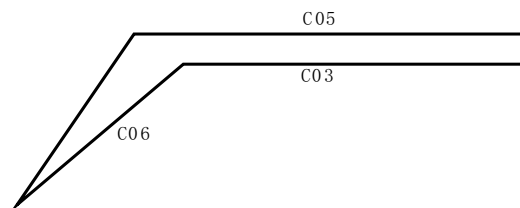

Figure 4-55 Schematic diagram of main channel parameters

Table 4-10 Description of main channel parameters

CHANNEL PARAMETER	DESCRIPTION OF PARAMETERS
C03	Main wire feed speed
C04	Main wire feed speed correction rate (the rate relative to current user JOB main wire feeding speed, which is only applicable to No.4 hot Starting arc JOB and No.5 hot filling arc crater JOB)
C05	Arc length factor for main wire feed speed
C06	Slope factor of main wire feed speed

Channel parameters C12~C15: direct current control parameters**Steps:**

Press the select button on the left to select “Channel”, and turn the Left knob to select the relevant channel parameter.

The direct current control parameters are shown in Figure 4-56, and for the description of these parameters, see Table 4-11.

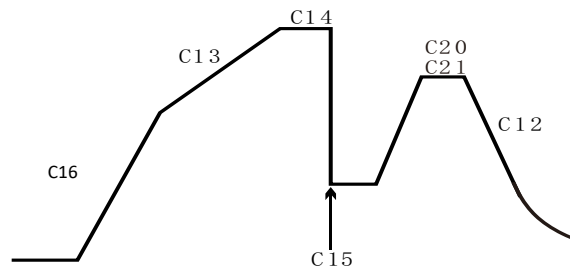
**Figure 4-56 Schematic diagram of direct current control parameters****Table 4-11 Description of direct current control parameters**

CHANNEL PARAMETER	DESCRIPTION OF PARAMETERS
C12	Direct current arc characteristic (adjustment) factor (the more positive, the steeper)
C13	Rising slope factor of short-circuit current (the more positive, the bigger)
C15	Sensitivity factor 1 low spatter welding (the more negative, the more sensitive)
C16	Weld penetration adjustment factor (-7~+7, with 0 as default)

Channel parameters C20~C29: pulse control direct parameters**Steps:**

Press the select button on the left to select “Channel”, and turn the left knob to select the relevant channel parameter.

The pulse control parameters are shown in Figure 4-57, and for the description of these parameters, see Table 4-12.

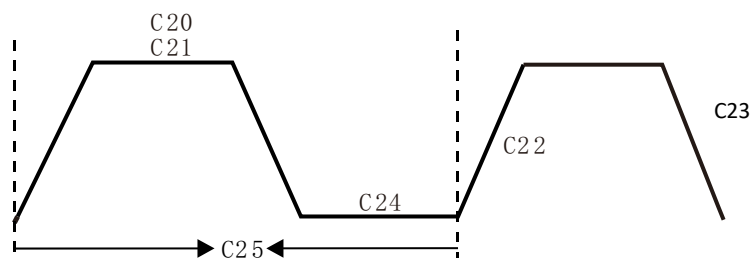

Figure 4-57 Schematic diagram of pulse control parameters

Table 4-12 Description of direct current control parameters

CHANNEL PARAMETER	Description of parameters
C20	Pulse peak current amplitude factor
C21	Pulse peak current time factor
C22	Rising slope factor of pulse current
C23	Declining slope factor of pulse current
C24	Basic pulse current factor
C25	High pulse frequency factor
C27	Pulse arc characteristic factor 2 (proportional to slope)
C28	Pulse arc adjustment factor (proportional to extension)
C29	Pulse arc length adjustment factor (proportional to length)

Channel parameters C30~C34: Synergy control direct parameters

Steps:

Press the select button on the left to select “Channel”, and turn the left knob to select the relevant channel parameter.

The synergy control parameters are shown in Figure 4-58, and for the description of these parameters, see Table 4-13.

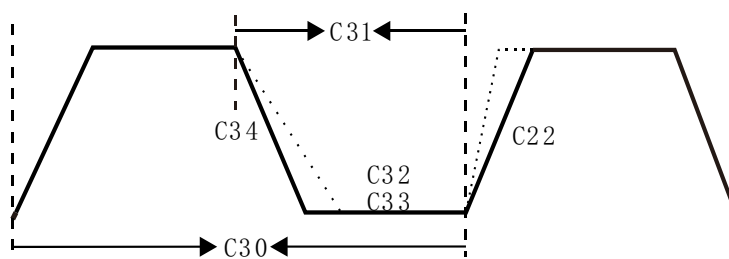

Figure 4-58 Schematic diagram of synergy control parameters

Table 4-13 Description of direct synergy control parameters

CHANNEL PARAMETER	DESCRIPTION OF PARAMETERS	SCOPE	PRECISION
C30	Synergy frequency	0.1~6.3(Hz)	0.1
C31	Duty cycle for wire feed speed of low-power section of double pulse	0~75(%)	5(%)
C32	Secondary wire feed speed rate	-50 ~ +200(%)	5(%)
C33	Arc length factor for wire feed speed of low-power section of double pulse	-30% ~ +30(%)	1(%)
C34	Slope factor of synergy wire feed speed	-7~7	1

Chapter 5 Communication interface with robot

5.1 Communication interface with robot

Artsen Plus/Pro series robotic models can be connected to a robot by the communication box, which is at the back of the welding power source. Robotic communication port is shown in Figure 5-1. All Artsen Plus/Pro series of welding power sources have the CAN communication interface, which is reserved for special customization and software upgrad; the communication box is shown in Figure 5-2.

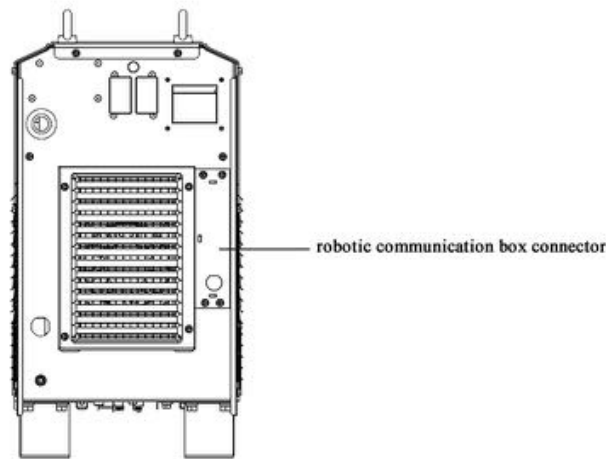

Figure 5-1 Robotic communication interface

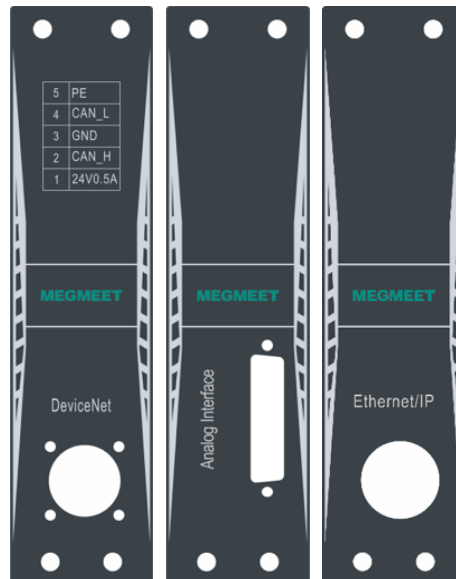

Figure 5-2 Communication Box

Table 5-1 List of communication box configuration

Name	Item code	Note
Analog communication box	R13401088	Optional
Digital communication box	R13401089	Optional
Ethernet/IP communication box	R13401091	Optional
EtherCAT communication box	/	Optional

5.2 Analog interface

Terminal pin sequence of DB25 is shown in Figure 5-3, and the pin definitions are shown in Table 5-2.

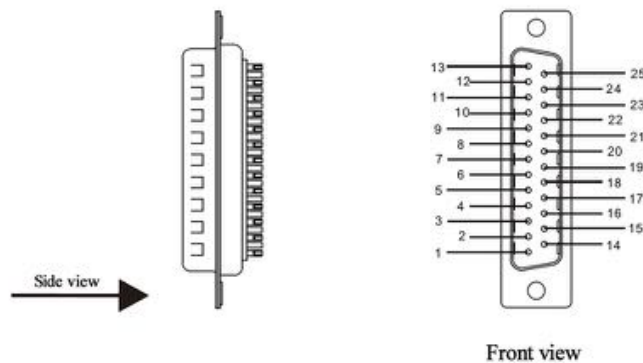
**Figure 5-3 Terminal pin sequence of DB25****Table 5-2 Communication terminal pin definitions of DB25**

Pin No.	Communication line color	Signal name	Function	Notes
1	Black 1	DC 24V power supply	DC 24 V power supplied by the robot to the welding power source.	Note 1
2	Black 2	Signal for starting arc	Signal comes from robot to welding power source, and low level is effective. (default)	Note 2
3	Black 3	Signal for reverse wire feeding	Signal comes from robot to welding power source, and low level is effective. (default)	Note 2
4	Brown 1	Signal for successful starting arc	Signal comes from welding power source to robot, and low level is effective. (default)	Note 3
5	Brown 2	Signal for being ready	Signal comes from welding power source to robot, and low level is effective. (default)	Note 3
6	Brown 3	Common ground for I/O signal	Common ground for pin 1,2,3,4,5,7,8,9,10 I/O signal	
7	Orange 1	Signal for inching feeding	Signal comes from robot to welding power source, and low level is effective. (default)	Note 2
8	Orange 2	Signal for robot emergent stop	Signal comes from robot to welding power source, low level is effective. (default)	Note 2
9	Orange 3	Signal for	Signal comes from robot to welding power	Note 2

		gas check	source, low level is effective. (default)	
10	Purple 1	Successful seam positioning signal	Signal comes from welding power source to robot, low level is effective. (default)	Note 3
11	Purple 2	Welding current signal	The analog signal from welding power source to robot, which is for feedback the actual value of welding current.	Note 4
12	Purple 3	Given current signal	The analog signal from robot to welding power source, which is the value of given current.	Note 6 Note 7
13	Blue 1	Common ground for analog signal	The common ground for analog signal from pin11 to pin 15.	
14	Blue 2	Welding voltage signal	The analog signal from welding power source to robot, which is for feedback the actual value of welding voltage.	Note 5
15	Blue 3	Given voltage signal	Analog signal, output given voltage value from robot to welding power source.	Note 8 Note 9
16	Blank	Reserved		
17	Blank	Reserved		
18	Pink 1	JJOB number control 1	Signal comes from dedicated machine or robot to welding power source, and for corresponding JOB number, see Table 5-3.	Note 2
19	Pink 2	JOB number control 2	Signal comes from dedicated machine or robot to welding power source, and for corresponding JOB number, see Table 5-3.	Note 2
20	Pink 3	JOB number control 3	Signal comes from dedicated machine or robot to welding power source, and for corresponding JOB number, see Table 5-3.	Note 2
21	Grey 1	common ground for I/O signal	The common ground for analog signal from pin18 to pin 23.	
22	Grey 2	Enabling seam positioning	Signal comes from robot to welding power source, low level is effective. (default)	Note 2
23	Blank	Reserved		
24	Blank	Reserved		
25	Blank	Reserved		

Table 5-3-3 JOB channel true values

JOB input port 3	JOB input port 2	JOB input port 1	Channel Number
0	0	0	Channel 0
0	0	1	Channel 1
0	1	0	Channel 2
0	1	1	Channel 3
1	0	0	Channel 4
1	0	1	Channel 5
1	1	0	Channel 6
1	1	1	Channel 7

Note: In the table, 0 means JOB port is unearth while 1 means the JOB port is earthed by a short circuit

manner.

Definitions of communication line colors

For explanation about definitions of communication line colors, see Figure 5-4.

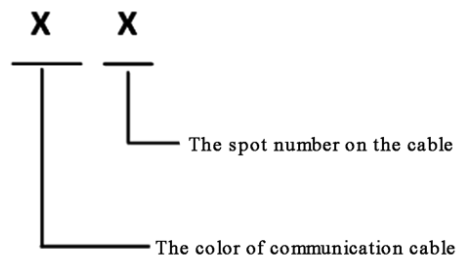

Figure 5-4 Explanation about communication line colors

For an example:

Black 3 means there are three points on the black line.

Explanations about notes on pin definitions

Note 1:

The voltage scope of 24V DC power provided by robot to welding power source should be limited to 20~30V.

Note 2:

Equivalent circuit of I/O signal transmission output from robot to welding power source is shown in Figure 5-5, with low level being effective. The robot work at low level that the voltage between I/O signal terminal + and signal terminal - is 0~5V; The robot will not work at high level that the voltage between I/O signal terminal + and signal terminal - is 18~24V. The voltage range of the I/O signal is 0~30V.

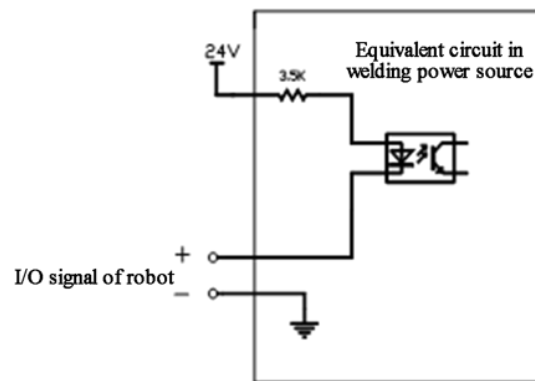

Figure 5-5 Equivalent circuit of signal from robot to welding power source

Note 3: The equivalent circuit for arc-starting I/O signal transmission is shown in figure 5-6. The arc starts successfully when the I/O signal output is at low level while the arc can not start when the I/O signal output is at high level. Starting arc

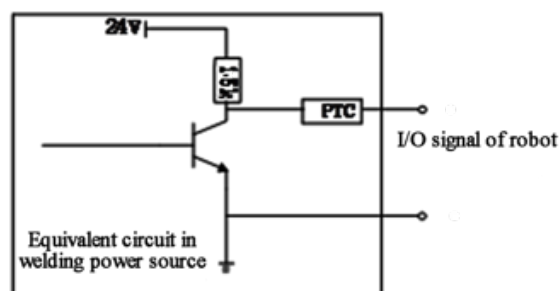

Figure 5-6 Equivalent circuit of I/O signal from welding power source to robot

5.2.1 Configuration of parameter graph

1. Corresponding relation of given current is shown in Figure 5-7.

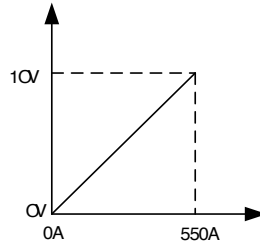

Figure 5-7 Corresponding relation of given current (Fanuc)

2. Corresponding relation of synergy voltage deviation is shown in Figure 5-8.

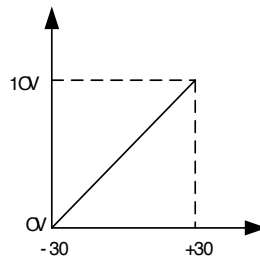

Figure 5-8 Corresponding relation of synergy voltage deviation (Fanuc)

3. Corresponding relation of given voltage at manual mode is shown in Figure 5-9.

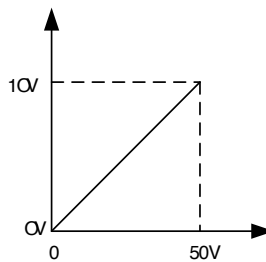

Figure 5-9 Corresponding relation of given voltage at manual mode (Fanuc)

5.3 DeviceNet

5.3.1 Definition of the connector pins

Aviation pin sequence of robot DeviceNet interface is shown in Figure 5-10.

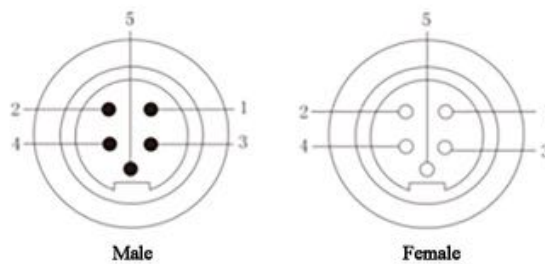

Figure 5-10 Aviation pin sequence

Aviation pin definitions of DeviceNet communication interface are shown in Table 5-4.

Table 5-4 Aviation pin definitions

Pin No.	Color	Signal name	Function
1	Red (18AWG)	24V power supply	Supply 24V power to the robot
2	White (22AWG)	CAN_H signal line	Communication line CAN_H
3	Black (18AWG)	GND	GND
4	Blue (22AWG)	CAN_L signal line	Communication line CAN_L
5	Shielding wire (18AWG)	Shielding wire	Enclosure PE

Notes

1.

The robot do not need to connect with the 24V power supply when the robot provide with the 24V power supply by itself.

2. 120Ω resistance should be connected between high level and low level of digital interface unless the robot already equipped with 120Ω resistance ;

5.3.2 Configuration of communication

Configuration of communication for DeviceNet communication interface is shown in Table 5-5.

Table 5-5 Configuration of communication for DeviceNet

Setting No.	Setting content	Setting value	Note
1	Baud rate	125Kbps (default)	250Kbps and 500Kbps as optional
2	Data length sent from main station of the polling area	12byte	Data length sent by robot
3	Response data from secondary station of the polling area	13byte	Data length replied by welding power source

5.3.3 Configuration of parameter graph

Parameter configuration graph of Megmeet and Fanuc

Given graph setting

1. Corresponding relation of given wire feeding speed is shown in Figure 5-11.

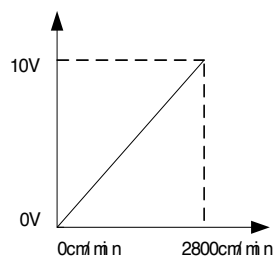
**Figure 5-11 Corresponding relation of given wire feeding**

2. Corresponding relation of given current is shown in Figure 5-12.

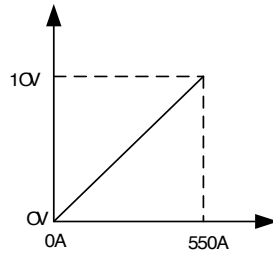

Figure 5-12 Corresponding relation of given current

3. Corresponding relation of synergy voltage deviation is shown in Figure 5-13.

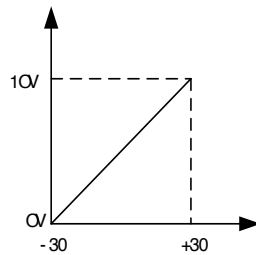

Figure 5-13 Corresponding relation of synergy voltage deviation

4. Corresponding relation of given voltage at manual mode is shown in Figure 5-14.

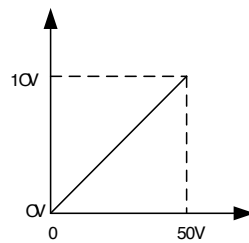

Figure 5-14 Corresponding relation of given voltage at manual mode

Feedback graph setting

1. Corresponding relation of real-time current feedback is shown in Figure 5-15.

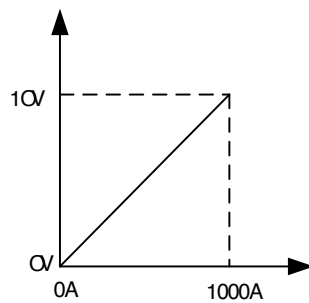

Figure 5-15 Corresponding relation of real-time current feedback

2. Corresponding relation of real-time voltage feedback is shown in Figure 5-16.

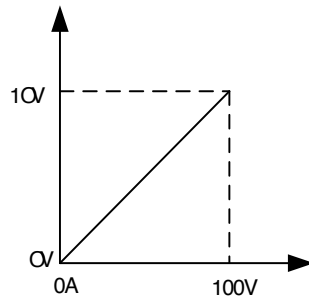

Figure 5-16 Corresponding relation of real-time voltage feedback

5.4 EtherNet/IP

5.4.1 Configuration of EtherNet/IP communication

EtherNet/IP communication configuration information is shown in Table 5-6.

Table 5-6 EtherNet/IP communication configuration information

Setting No.	Setting content	Setting value	Note
1	Name/IP address	192.168.0.2 (default)	192.168.0.2-192.168.0.63 (IP addresses of main station and second station should be at the same section)
2	Input size (bytes)	37	
3	Output size (bytes)	37	
4	RPI	20	
5	Assembly instance (input)	100	
6	Assembly instance (output)	150	
7	Configuration instance	1	
8	Manufacturer ID	90	
9	Equipment type	43	
10	Product code	55	

Notes

1. The IP address of the main station is the IP address of the robot, and it has to be at the same section with the IP address of the welding power source. (Can not using the same ID address as the welding power source.)
2. The IP address of the slave station is the same as the welding power source IP address, and 192.168.0.2 by default. If it is not repetitive with the robot MAC ID, such ID may be set at any value in the range of 0~63 in N01.
3. EtherNet/IP communication type is SCN (scanner). The power source can not connect to the robot when EtherNet/IP communication configuration is complete. It is needed to ping the IP addresses of the main station (robot) and slave station (welding power source) at the demonstrator page of the robot, to ensure there is a proper link.

5.4.2 Advanced configuration of EtherNet/IP communication

Advanced configuration of EtherNet/IP communication interface is shown in Table 5-7.

Table 5-7 Advanced configuration of EtherNet/IP communication

Setting No.	Setting content	Setting value	Note
1	I/O data type	8 bytes	
2	Timeout multiplier	4	
3	Reconnect	Invalid	
4	Main version	1	
5	Secondary version	35	
6	Alarm severity	Stopped	
7	Quick link	Invalid	
8	Initiator to target RPI	20	
9	Transmission type from destination to initiator	Unicast	
10	Destination to initiator RPI	20	
11	Connection type: type O=>T format	Running/idle data	
12	Connection type: type O=>T format	Modeless	
13	Configure character string status size (byte)	0	

5.4.3 Configuration of parameter graph

EtherNet/IP Parameter configuration graph of Megmeet and Fanuc.

Given graph setting

1. Corresponding relation of given wire feeding speed is shown in Figure 5-17.

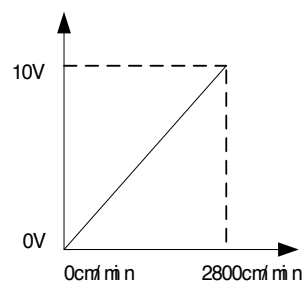

Figure 5-17 Corresponding relation of given wire feeding

2. Corresponding relation of given current is shown in Figure 5-18.

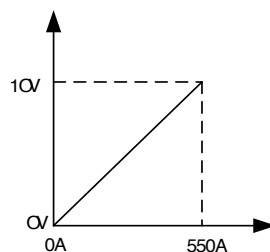

Figure 5-18 Corresponding relation of given current

3. Corresponding relation of synergy voltage deviation is shown in Figure 5-19.

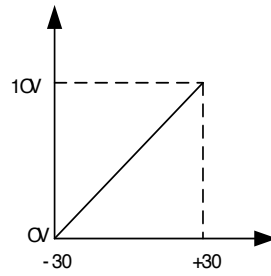
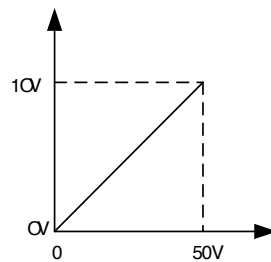

Figure 5-19 Corresponding relation of synergy voltage deviation

4. Corresponding relation of given voltage at manual mode is shown in Figure 5-20.



**Figure 5-20 Corresponding relation of given voltage at manual mode
Feedback graph setting**

1. Corresponding relation of real-time current feedback is shown in Figure 5-21.

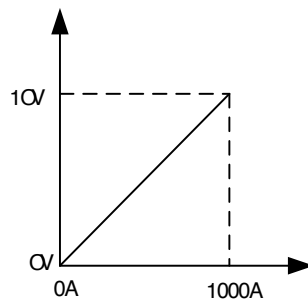

Figure 5-21 Corresponding relation of real-time current feedback

2. Corresponding relation of real-time voltage feedback is shown in Figure 5-22.

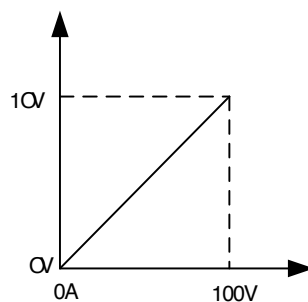

Figure 5-22 Corresponding relation of real-time voltage feedback

5.5 Data definitions for application layer

Data definitions for application layer are applicable to DeviceNet & EtherNet IP.

Data definitions for application layer of DeviceNet & EtherNet IP are shown in Table 5-8.

Table 5-8 Data definitions for application layer of DeviceNet & EtherNet IP

Signals sent from robot to welding power source			
Data bits	Data description	Scope	Note
E01	Start welding		
E02	Robot is ready		
E03	Bit0 welding power source working mode		0. DC synergy mode 1. Pulse synergy mode 2. JOB mode 3. Intermittent welding
E04	Bit1 welding power source working mode		
E05	Bit2 welding power source working mode		
E06	Reserved		
E07	Reserved		
E08	Reserved		
E09	Gas test		
E10	Inching		
E11	Reverse wire-drawing and feeding		
E12	Failure reset		
E13	Enabling seam positioning		
E14	Reserved		
E15	Reserved		
E16	Reserved		
E17-E24	JOB mode: JOB number		
E25-E31	Reserved		
E32	Reserved		
E33-E48	Given current/wire feeding speed for welding		
E49-E64	Given voltage/synergy correction for welding		
E65-E72	Reserved		
E73-E80	Reserved		
E81	Reserved		
E82	Reserved		
E83	Reserved		
E84	Reserved		
E85	Reserved		
E86	Reserved		
E87-E96	Reserved		
Signals replied by welding power source to robot			
Data bits	Data description	Scope	Note
A01	Successful starting arc		
A02	Reserved		
A03	Welding status		
A04	Reserved		
A05	Reserved		
A06	Welding power source failure		
A07	Communication ready		
A08	Reserved		
A09-A16	Error code		
A17-A24	Reserved		
A25	Successful seam positioning signal		
A26	Reserved		
A27	Reserved		
A28	Wire-feeder in normal situation		

A29	Reserved		
A30	Reserved		
A31	Reserved		
A32	Given setting over range		
A33-A48	Real-time voltage for welding		
A49-A64	Real-time current for welding		
A65-A72	Reserved		
A73-A80	Reserved		
E81-E96	Real-time wire feeding speed		

5.6 Operational procedure of robot

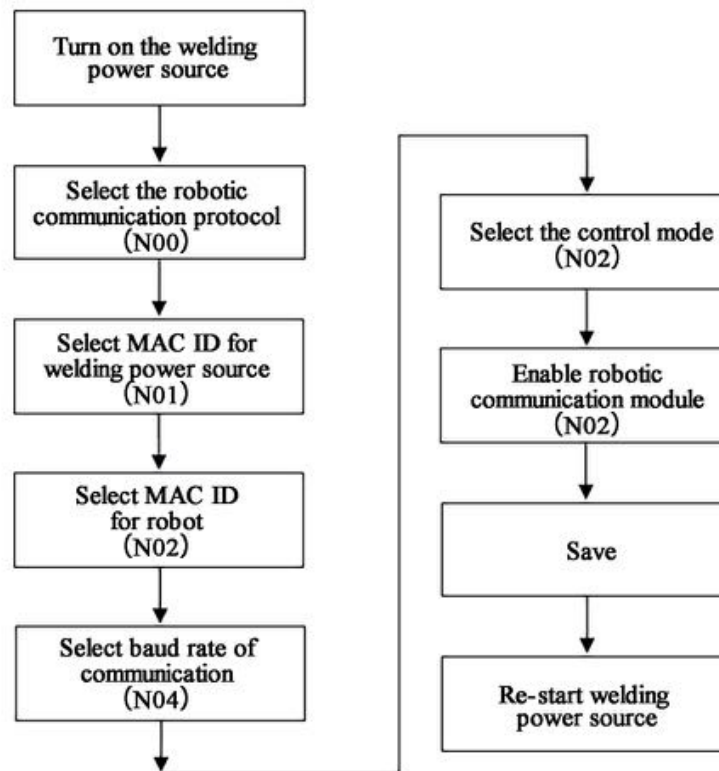

Figure 5-23 Operational procedure of robot

Notes

1. The control mode sent by robot should be consistent with the control mode selected on the panel of the welding power source.
2. If the JOB parameters need to be modified at the JOB calling mode, it is needed to exit the JOB calling mode firstly, and enter the panel control mode (N mode) to make any modification. Remember to save the setting before switching the JOB number.
3. Upon resetting the signal of robot ready, The welding power source will go to the cratercrater status at first after resetting the ready signal for the robot
4. For the given graphs and feedback graphs, please refer to the description of the relevant communication protocols.
5. The robot only responses to “Given current/wire feeding speed” selection that set on the panel of the welding power source instead of the selections that made in the communication protocols.

Chapter 6 Error diagnosis

6.1 Error code of welding power source and solution

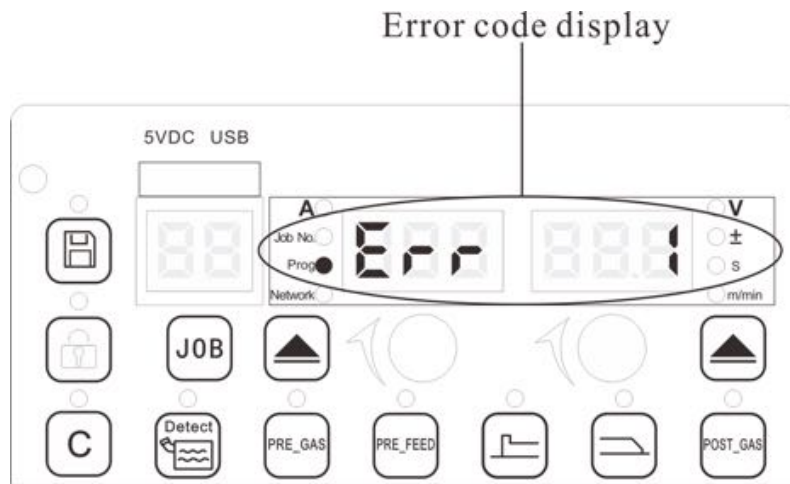

Figure 6-1 Error code view

Error code, cause and solution for welding power source are shown in Table 6-1.

Table 6-1 Error code, cause and solution for welding power source

Error code	Error name	Solution
Err1	EEPROM error in the DSP board.	Restart the power source or restore to factory settings, or contact the factory.
Err2	DSP board illegal	Contact the factory.
Err3	Internal communication error 1	Check the communication between the DSP board and the communication box.
Err4	Internal communication error 2	Check the communication between the DSP board and the motor driving board.
Err5	Reserved	
Err6	Internal communication error 3	Check the communication lines between the DSP board and the front panel.
Err7	The initial status for the torch error	Check the welding torch switch signals.
Err8	Input over voltage for welding power source	Check the connection for the welding power source/ grid problem
Err9	Input under voltage for welding power source	Check the connection for the welding power source/ grid problem
Err10	Bus for the welding power source over voltage.	Check the connection for the welding power source/ grid problem
Err11	Primary side of the transformer over current.	Check whether the output side of the welding power source is shorted, or contact the factory.
Err12	Welding power source over heat.	Check whether the welding power source is over loaded, or the air duct is blocked.
Err13	Secondary side of transformer over current for the welding power source	Check whether there is an overload or a short circuit at the output side of welding power source.
Err14	Output terminal over heat	Check whether the output terminals of welding power screw tight, or the cables are too thin.
Err15	Secondary side of the transformer under voltage	Check if the output side of welding power source is shorted.
Err16	Hall sensor abnormal for the	Check the hall cable for the welding power source.

	welding power source	
Err17	Over current for motor drive	Check whether the motor is blocked or the motor drive is shorted.
Err18	Output under voltage for motor	Check whether the motor is blocked or the encoder is loose.
Err19	The drive for the valve abnormal	Check whether the cables for valve open circuit/short circuit.
Err20	Over current for the wire-pulling motor	Check whether the wire-pulling motor is blocked.
Err21	Water flow inspection switch for the water tank failure.	Check the water flow inspection switch of the water tank.
Err22	Reserved	/
Err23	JOB illegal	Check whether switching to the user JOB number during normal welding
Err24	Reserved	
Err25	No water flowing through the water tank	Check whether the water tank filled with water and check the water path.
Err27	External communication disconnected	Check whether the network parameters are set properly or correctly wiring.
Err28	External communication abnormal	Check whether the network parameters are set properly or correctly wiring.
Err29	Under voltage for the wire-pulling motor	Check whether the wire-pulling motor is blocked or the wire-pulling motor driving is short-circuited.
Err30	Settings exceeding the scope	Check whether the given signals of the welding power source exceed the relevant scope.
Err31	Robot host is not ready	Check whether there is a failure on the robot host.
Err32	Internal communication error 4	Check the communication lines between the DSP board and the setup panel.
Err33	EEPROM in the front panel error	Restart the machine or contact the factory.
Err34	Button stuck in the front panel	Check the buttons on the front panel
Err35	Illegal welding power source display panel	Check the communication lines between the DSP board and the front panel, or contact the factory.
Err36	Communication abnormal on the front panel of the wire-feeder	Check the communication lines of the front panel for the wire-feeder.
Err37	Wire-feeder front panel EEPROM error	Restart the machine or contact the factory.
Err38	Button stuck in the front panel of wire-feeder	Check the buttons on the front panel of wire-feeder.
Err41	Illegal front panel for the welding power source	Contact the factory.
Err42	Illegal motor driving board	Contact the factory.
Err43	DSP board illegal	Contact the factory.
Err44	Illegal setup panel of the wire-feeder	Contact the factory.
Err45	Illegal communication board	Contact the factory.
Err52	Software version for motor driving unmatched	Upgrade the relevant firmware of the welding power source or contact the factory.
Err53	Software version for main control panel unmatched	Upgrade the relevant firmware of the welding power source or contact the factory.
Err54	Software version for wire-feeder front panel unmatched	Upgrade the relevant firmware of the welding power source or contact the factory.
Err57	Software version for communication switch panel unmatched	Upgrade the relevant firmware of the welding power source or contact the factory.

6.2 Error code in firmware upgrading and solution

Error code, cause and solution in firmware upgrading of the welding power source is shown in Table 6-2.

Table 6-2 Error code, cause and solution in firmware upgrading of the welding power source

Error code	Error name	Solution
E1	Reserved	/
E2-2	Internal communication error 1	Check the communication lines between the front panel of welding power source and the motor driving panel.
E2-3	Internal communication error 2	Check the communication lines between the front panel of welding power source and the main control panel.
E2-7	Internal communication error 3	Check the communication lines between the front panel of welding power source and the communication switch panel.
E3	File error	Check whether the file is correct.
E4	USB connection error	Check whether the USB flash disk has a good contact.
E5	Flash reading/writing error	Contact the factory.
E6	Reserved	/
E7	APP abnormal	Contact the factory.
E8	USB flash disk reading/writing error	Contact the factory.
E9	EEPROM reading/writing error	Contact the factory.

Chapter 7 Maintenance

7.1 Daily check

Warning about safety

Daily check should be carried out after disconnecting the power supply of electric distribution box and the power supply of this machine (except for the appearance check which do not need to touch the conductor) to avoid electric shock, burn and other personal injury.

Notes for usage:

1. Daily checking is very important for keeping the high performance and safe running of the welding machine.
2. Do the daily check according to the following list and do cleaning or replacing when necessary.
3. In order to ensure the high performance of this welding power source, using the components provided or recommended by Shenzhen Megmeet Welding Technology Co., Ltd. when replacing the components.

Table 7-1 Daily check for welding power source

Item	Key points of Check	Note
Front panel	Whether any mechanical part is damaged or loose; Whether the cable wiring at the bottom is firmly fixed; Whether the indicator for failure is flashing.	Terminal cover at the bottom should be one item for the periodic check. If there is any non-conformity, then internal check of welding power source should be done, or further fixing should be done, or some part should be replaced.
Back panel	Whether the terminal cover of the input power supply is good; Whether the ventilation hole is smooth without any foreign object.	
Top panel	Check whether the eyebolt or other bolts are loose.	Fix or replace the component if there is any unqualified situation.
Bottom panel	Check whether the wheel are damaged or loose.	
Side panel	Check whether the side panels are loose.	
Routine	Check whether there is any discoloration on the panel. Confirm that is no overheat situation on the panel. Confirm the fan running without any noise. Check whether there is any irregular particular smell, vibration or noise when welding	The internal check should be carried out if there is any problem in routine checking.

Cable

Table 7-2 Daily check for cable

Item	Key points of Check	Note
Ground cable	Check whether the ground cable is connected, including ground cable and PE.	Fix or replace the cable if there is any unqualified situation.
Positive output cable	Check whether the insulation layer of cable is worn or any exposure of conductive part. Check whether there is any extension of cable owing to irregular external force. Check whether the connection between the working piece and the relevant cable is connected firmly.	Follow the actual situation to choose a proper way for checking the cable.

Other components

Table 7-3 Daily check for other components

Item	Key points of Check	Note
Welding torch	Carry out daily check according to usage instructions for welding torch.	/

Wire-feeder	Carry out daily check according to usage instructions for wire-feeder.	/
Water tank	Carry out daily check according to usage instructions for water tank.	
Gas meter	Carry out daily check according to usage instructions for gas meter.	/
Gas hose	Check whether connection is form, and when soft clamp is used, check whether there is looseness, whether soft hose is worn or damaged.	Fix or change a gas hose if there is any unqualified situation.

7.2 Periodic check

Warning about safety

1. In order to ensure safety, periodic check should be done by a qualified professional person.
2. Periodic check should be carried out after disconnecting the power supply of electric distribution box and the power supply of this machine to avoid electric shock, burn and other personal injury.
3. Wait about 5 minutes(capacitor charge) before periodic check.

Notes on operation

1. Wearing a anti-static device or toching the metal part of the case to avoid the static damage for semiconductor or circuit board before touching the internal circuit board or any conductor.
2. Do not use the solvents other than the neutral detergents for household use to clean the plastic component.

Periodic check plan

1. Periodic check should be carried out to ensure long-term normal use of this equipment.
2. Periodic check should be thorough, including internal check and cleaning of the equipment.
3. Periodic check should usually be done on a basis of every 6 months; periodic check should be done on a basis of every 3 months if there is much dust or oily fume on the welding site.

Contents of periodic check

User may add check items according to actual situation except for the following item:

1. Internal dust removal for welding power source.

Firstly remove the top panel and side panels of welding power source, and then use the dry compressed air to blow the internal spill and dust, which accumulated in the welding power source, finally remove the dirt and foreign object that are hard to blow away.

Note

Accumulation of dust will affect the heat dissipation, which may cause the over heat protection.

2. Welding power source checking

Remove the top panel and side panels of welding power source to check whether there is any odor, color fading or over-temperature damage phenomenon, and the looseness of the connections.

3. Cables and gas hose checking

Check the ground cable, other cables and gas hose and so on. More thorough check should be done based on the item of daily check, and routinely further tightening and fixing.

Dielectric strength testing and insulation testing

Dielectric strength testing and insulation testing should be implemented by the after-sales engineer of our company or someone who has the professional knowledge of electrics and welding power source.

Rules for operations

1. Turn off the power distribution box.
2. Dismantle all the grounding wires on the enclosure.
3. Dismantle all the peripherals such as wire-feeder to make the welding power source a separate object.
4. Short circuit the three input terminals with a conductor.
5. Set the switch of welding power source at “ON” position.
6. Short circuit the positive output terminal, negative output terminal and 19 cores socket (except for 19th core) together with a conductor.,
7. Using the same conductor that sectional area no less than 1.23mm² to do the short circuit operation above.

 **Note**

All modifications and treatments for dielectric strength testing should be undone after dielectric strength being completed.

7.3 After-sales service

Warranty card

There is a warranty card for every equipment, and please fill up the contents of your warranty card. Please carefully read the contents of warranty card and keep the card in a safe custody.

Repair

User should firstly carry out the check according to the contents in **6.1 Error code of welding power source** and solution of **Chapter 6** and basically do trouble-shooting for the failure or record the failure information.

If it is needed to repair or replace some part, please contact the local distributor. Use the parts or accessories provided or recommended by Shenzhen Megmeet Welding Technology Co., Ltd.

For the product, we provide one year of warranty. Warranty period should be calculated from the date that is recorded on the warranty card or the invoice for purchasing this product. Any product damage caused by improper use by user will not fall within the scope of warranty, but may be treated in a normal repairing manner.

Appendix 1 Technical specification

Appendix 1-1 Technical specification of welding power source

Welding power source	Unit	Artsen Plus/Pro 350D/P/Q	Artsen Plus/Pro 400D/P/Q	Artsen Plus/Pro 500 (H) D/P/Q
Control mode	-	Digital control	Digital control	Digital control
Rated input voltage/phase number	-	3-phase 380V AC	3-phase 380V AC	3-phase 380V AC
Input power frequency	Hz	45~65Hz	45~65Hz	45~65Hz
Rated input capacity	kVA/kW	15kVA/12.7kW	16kVA/14kW	24kVA/22.3kW
Power factor	-	0.94	0.94	0.93
Output feature	-	CV	CV	CV
Rated output current	A	350A	400A	500A
Rated output voltage	V	31.5V	34V	39V
Rated duty cycle	%	DC 60%@350A	DC 100%@400A	DC 60%@500A 500H: DC100%@500A
Open circuit voltage	V	85V	85V	85V
Output current	A	30A~350A	30A~400A	30A~500A
Output voltage	V	12V~45V	12V~45V	12V~45V
Degree of protection	-	IP23S	IP23S	IP23S
Ambient temperature		-10℃~40℃	-10℃~40℃	-10℃~40℃
Insulation level	-	H	H	H

Appendix 1-2 Technical specification of wire-feeder

Wire-feeder		
Control mode for wire feeding transmission	/	Photoelectric encoder feedback/back electromotive force control
Rated current	A	4.5A
Rated voltage	V	24V
Wire feeding speed	m/min	0.8~24 m/min.
Wire-feeding wheel diameter	mm	0.8~1.6
Welding wire wheel type	/	All standard wire wheels
Driving device	/	Four-wheel wire-feeding driving device
Welding torch port	/	European port/Japanese port (optional)
Water cooling port	/	Robotic European port (optional)

Appendix 1-3 Technical specification of water tank

Water tank		
Input voltage	V	400V AC±10%
Cooling water volume	L	10L
Cooling water flow	L/min	3.5L/min
Cooling water maximum lift head	m	26m
Cooling capacity	KW	1.5KW

Appendix 2 Electrical diagram

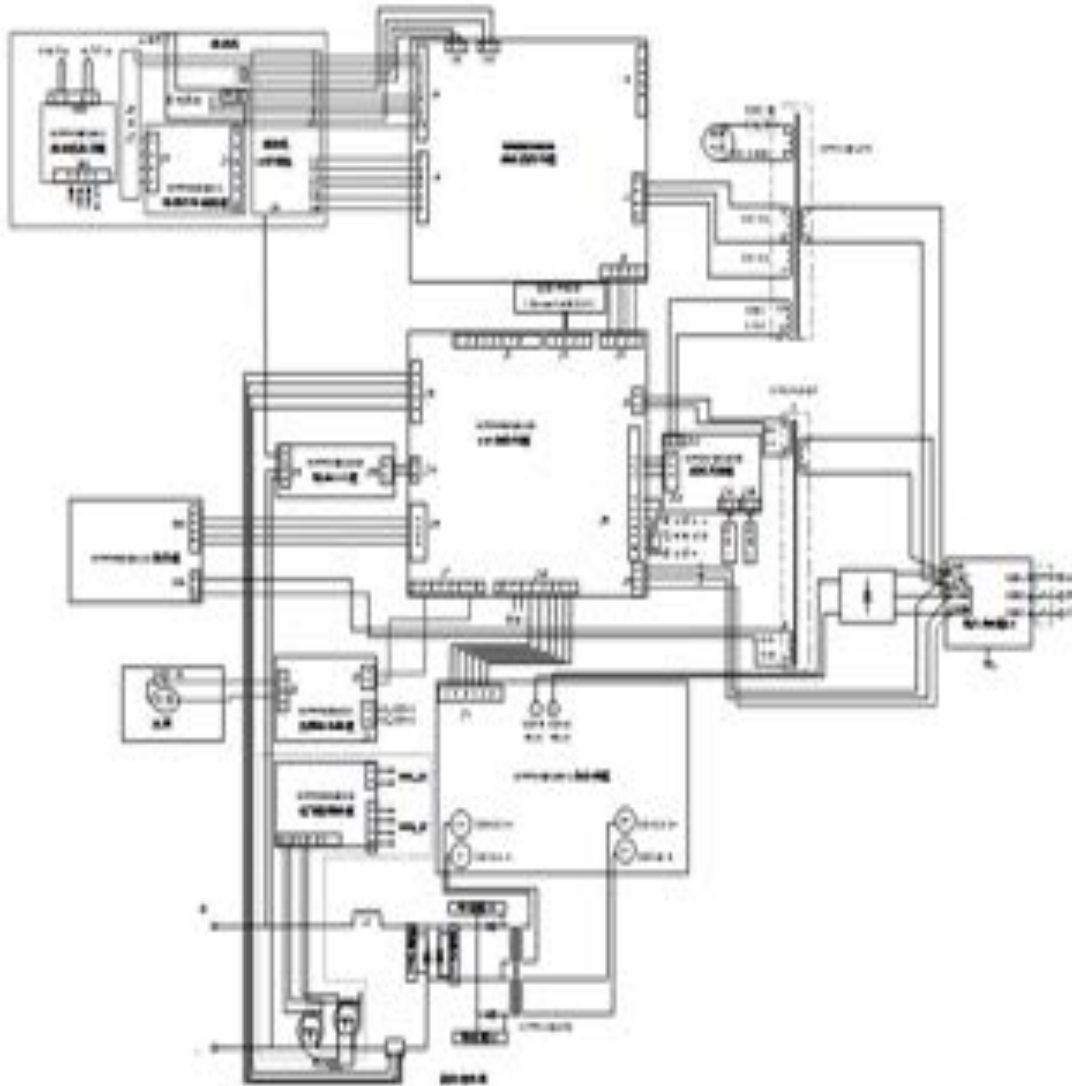

- Notes:** 1. High-voltage seam-positioning function is only provided for the robotic models;
2. The part in the dotted line frame is only for Artsen Plus series.

Appendix 3 System composition & Accessories Systematic configuration

Appendix 3-1 Systematic configuration for Artsen Plus manual welding power source

Name	Configuration	Quantity	Note	Model		
				Artsen Plus 350/400/500D	Artsen Plus 350/400/500P	Artsen Plus 350/400/500Q
Welding power source	Standard	1		●	●	●
Wire-feeder	Standard	1	Available in Japanese port/European port	●	●	●
Welding torch	Optional	1	Available in push-pull torch/low spatter torch	○	○	○
Water tank	Optional	1	Available in 5m/10m/15m/20m/25m water hose.	○	○	○
Combination cable	Standard	1	Standard length for 3m, available in 5m/10m/15m/20m/25m.	●	●	●
Working piece side positive output cable (ground cable)	Standard	1	Standard length for 1.8m	●	●	●
voltage feedback cable	Standard	1	Standard length for 5m, available in 15m.	●	●	●
Aluminum alloy wire-feeding spare parts package	Optional	1		○	○	●
Welding trolley	Optional	1		○	○	○
Gas instrument	Optional	1		○	○	○

Appendix 3-2 Systematic configuration for Artsen Pro manual welding power source

User manual for Artsen Plus/Pro series fully digital IGBT converter CO₂/MAG/MIG multi-function welding power source

Configuration				Model		
Name	Configuration	Quantity	Note	Artsen Pro 400/500(H)D	Artsen Pro 400/500(H)P	Artsen Pro 400/500(H)Q
Welding power source	Standard	1		●	●	●
Wire-feeder	Standard	1	Available in Japanese port/European port	●	●	●
Welding torch	Optional	1	Available in push-pull torch/low spatter torch	○	○	○
Water tank	Optional	1	Available in 5m/10m/15m/20m/25m water hose.	○	○	○
Combination cable	Standard	1	Standard length for 3m, available in 5m/10m/15m/20m/25m.	●	●	●
Working piece side positive output cable (ground cable)	Standard	1	Standard length for 1.8m.	●	●	●
voltage feedback cable	Standard	1	Standard length for 5m, available in 1.5m.	●	●	●
Aluminum alloy wire-feeding spare parts package	Optional	1		○	○	●
Welding trolley	Optional	1		○	○	○
Gas instrument	Optional	1		○	○	○

Note: ● Standard ○ Optional

Appendix 3-3 Systematic configuration for Artsen Plus robotic welding power source

Name	Configuration	Quantity	Note	Model		
				Artsen Plus 350/400/500DR	Artsen Plus 350/400/500PR	Artsen Plus 350/400/500QR
Robotic welding power source	Standard	1		●	●	●
Robotic wire-feeder	Standard	1	Available in Japanese port/European port	●	●	●
Water cooling connector for robotic wire-feeder	Optional	1	European port	○	○	○
Analog port	Standard	1		●	●	●
Digital port	Standard	1		●	●	●
Ethernet port	Optional	1		○	○	○
Welding torch	Optional	1	Available in push-pull torch/low spatter torch.	○	○	○
Water tank	Optional	1	Available in 5m/10m/15m/20m/25m water hose.	○	○	○
Combination cable for robotic wire-feeder	Standard	1	Standard length for 3m, available in 5m/10m/15m/20m/25m.	●	●	●
Control cable for robot	Standard	1		●	●	●
Working piece side positive output cable (ground cable)	Standard	1	Standard length for 1.8m.	●	●	●
voltage feedback cable	Standard	1	Standard length for 5m, available in 15m.	●	●	●
Aluminium alloy wire-feeding spare parts package	Optional	1		○	○	●
Welding trolley	Optional	1		○	○	○
Gas instrument	Optional	1		○	○	○

Appendix 3-4 Systematic configuration for Artisen Pro robotic welding power source

Name	Configuration	Quantity	Note	Model		
				Artisen Pro 350/400/500(H)DR	Artisen Pro 350/400/500(H)PR	Artisen Pro 350/400/500(H)QR
Robotic welding power source	Standard	1		●	●	●
Robotic wire-feeder	Standard	1	Available in Japanese port/European port	●	●	●
Water cooling connector for robotic wire-feeder	Optional	1	European port	○	○	○
Analog port	Standard	1		●	●	●
Digital port	Standard	1		●	●	●
Ethernet port	Optional	1		○	○	○
Welding torch	Optional	1	Available in push-pull torch/low spatter torch	○	○	○
Water tank	Optional	1	Available in 5m/10m/15m/20m/25m water hose.	○	○	○
Combination cable for robotic wire-feeder	Standard	1	Standard length for 3m, available in 5m/10m/15m/20m/25m.	●	●	●
Control cable for robot	Standard	1		●	●	●
Working piece side positive output cable (ground cable)	Standard	1	Standard length for 1.8m.	●	●	●
voltage feedback cable	Standard	1	Standard length for 5m, available in 15m.	●	●	●
Aluminum alloy wire-feeding spare parts package	Optional	1		○	○	●
Welding trolley	Optional	1		○	○	○
Gas instrument	Optional	1		○	○	○

Note: ● Standard ○ Optional

Appendix 4 Structural Illustration

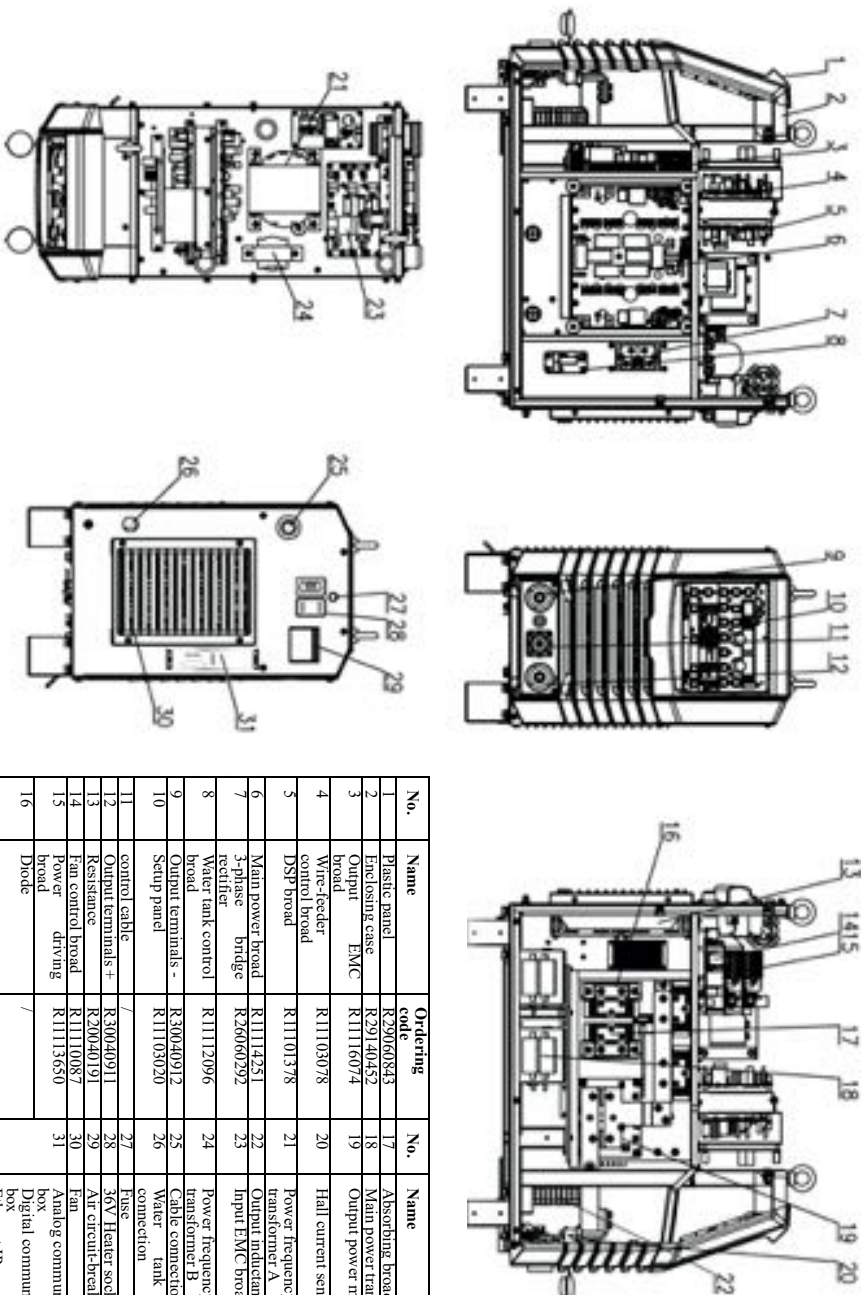

Figure 1 Structure list

No.	Name	Ordering code	No.	Name	Ordering code
1	Plastic panel	R29060843	17	Absorbing board	R11110090
2	Enclosing case	R29140492	18	Main power transformer	R26060369
3	Output EMC board	R11116074	19	Output power module	R27060017
4	Wire-feeder control board	R111103078	20	Hall current sensor	R23040011
5	DSP board	R111101378	21	Power frequency transformer A	R22071516
6	Main power board	R11114251	22	Output inductance	R11113739
7	3-phase bridge rectifier	R26060292	23	Input EMC board	R23010894
8	Water tank control board	R11112096	24	Power frequency transformer B	/
9	Output terminals -	R30040912	25	Cable connection	/
10	Setup panel	R11103020	26	Water tank cable connection	/
11	control cable	/	27	Fuse connection	R27010154
12	Output terminals +	R30040911	28	36V Heater socket	R30040882
13	Resistance board	R20040191	29	Air circuit-breaker	/
14	Fan control board	R11110087	30	Fan	R34020011
15	Power driving board	R11113650	31	Analog communication box	R13401088
16	Diode board	/		Digital communication box	R13401089
				Ethernet IP communication	R13401091

<p>MEGMEET Shenzhen Megmeet Welding Technology Co., Ltd. Warranty card for welding power source</p>		<p>MEGMEET Shenzhen Megmeet Welding Technology Co., Ltd. Warranty card for welding power source</p>	
Username:		Username:	
Detailed address:		Detailed address:	
Post code:	Contact:	Post code:	Contact:
Telephone:	Fax:	Telephone:	Fax:
Machine model:		Machine model:	
Power:	Machine number:	Power:	Machine number:
Contract number:	Purchasing date:	Contract number:	Purchasing date:
Service entity:		Service entity:	
Contact:	Telephone:	Contact:	Telephone:
Reparer:	Telephone:	Reparer:	Telephone:
Repairing date:		Repairing date:	
User's valuation of service quality: <input type="checkbox"/> Excellent <input type="checkbox"/> Good <input type="checkbox"/> Normal <input type="checkbox"/> Not good		User's valuation of service quality: <input type="checkbox"/> Excellent <input type="checkbox"/> Good <input type="checkbox"/> Normal <input type="checkbox"/> Not good	
Other opinion:		Other opinion:	
User's signature: date:		User's signature: Date:	
Revisit record of customer service center: <input type="checkbox"/> Revisiting by call <input type="checkbox"/> Revisiting by letter		Revisit record of customer service center: <input type="checkbox"/> Revisiting by call <input type="checkbox"/> Revisiting by letter	
Other:		Other:	
Technical support engineer's signature: Date:		Technical support engineer's signature: Date:	
Note: This card will be invalid if user cannot be revisited.		Note: This card will be invalid if user cannot be revisited.	

Notes to user

Notes to user

<p>1. The warranty scope means only welding power source.</p> <p>2. Warranty period is of one year. If welding power source fails or is damaged under proper using condition within the warranty period, our company will provide repairing service free of charge.</p> <p>3. Warranty period is calculated from the date when welding power source leaves factory; serial number of welding power source is only basis to judge its warranty period and if there is no serial number of welding power source, then the equipment will be treated as falling out of warranty period.</p> <p>4. If there is one of the following circumstances within the warranty period, we will still collect some repairing charge:</p> <ul style="list-style-type: none"> ■ Welding power source failure due to any operation not complying with User Manual; ■ Welding power source damage due to fire, flood or irregular voltage; ■ Welding power source damage due to abnormal function using. <p>5. Service charge will be calculated according to actual charge; if there is any contract for the purpose, then such contract should prevail.</p> <p>6. Please carefully keep this card and present it to the service entity when warranted repair is needed.</p> <p>7. If you have any question, you may contact the relevant distributor, or directly contact our company.</p> <p>Shenzhen Megmeet Welding Technology Co., Ltd. Customer service center</p> <p>Floor 5th, Block B, Unisplendour Information Harbour, Langshan Road, North Zone, Science and Technology Park, Nanshan District, Shenzhen, Guangdong Province Post code: 518057 Customer service hot line: 4006662163</p>	<p>1. The warranty scope means only welding power source.</p> <p>2. Warranty period is of one year. If welding power source fails or is damaged under proper using condition within the warranty period, our company will provide repairing service free of charge.</p> <p>3. Warranty period is calculated from the date when welding power source leaves factory; serial number of welding power source is only basis to judge its warranty period and if there is no serial number of welding power source, then the equipment will be treated as falling out of warranty period.</p> <p>4. If there is one of the following circumstances within the warranty period, we will still collect some repairing charge:</p> <ul style="list-style-type: none"> ■ Welding power source failure due to any operation not complying with User Manual; ■ Welding power source damage due to fire, flood or irregular voltage; ■ Welding power source damage due to abnormal function using. <p>5. Service charge will be calculated according to actual charge; if there is any contract for the purpose, then such contract should prevail.</p> <p>6. Please carefully keep this card and present it to the service entity when warranted repair is needed.</p> <p>7. If you have any question, you may contact the relevant distributor, or directly contact our company.</p> <p>Shenzhen Megmeet Welding Technology Co., Ltd. Customer service center</p> <p>Floor 5th, Block B, Unisplendour Information Harbour, Langshan Road, North Zone, Science and Technology Park, Nanshan District, Shenzhen, Guangdong Province Post code: 518057 Customer service hot line: 4006662163</p>
---	---